



Model	1012EMH	2012EMH	3024EMH	5048EMH	
Input	Input Sources	L+N+PE			
	Rated Input Voltage	220/230/240VAC			
	Voltage Range	90-280VAC±3V(APL Mode)170-280VAC±3V(UPS Mode)			
	Frequency	50Hz/60Hz(Auto Adaptive)			
Output	Rated Capacity	1000W	1600W	3000W	5000W
	Output Voltage	220/230/240VAC±5%			
	Output Frequency	50/60Hz±0.1%			
	Waveform	Pure Sine Wave			
	Transfer Time (adjustable)	Computers(UPS Mode)10ms, Appliance(APL Mode)20ms			
	Peak Power	2000VA	3200VA	6000VA	10000VA
	Peak Efficiency (battery Mode)	>94%	>94%	>94%	>94%
Battery	Battery Voltage	12Vdc	12Vdc	24Vdc	48Vdc
	Constant Charging Voltage(Adjustable)	14.1Vdc	14.1Vdc	28.2Vdc	56.4Vdc
	Floate Charging Voltage(Adjustable)	13.5Vdc	13.5Vdc	27Vdc	54Vdc
Chargers	PV Charging Mode	MPPT	MPPT	MPPT	MPPT
	MAX PV Input Power	1000W	2000W	3000W	5000W
	MPPT Tracking Range	30~450Vdc	40~500Vdc	40~500Vdc	40~500Vdc
	Best voltage	300~400Vdc	300~400Vdc	300~400Vdc	300~400Vdc
	MAX.PV Input Voltage	400Vdc	500Vdc	500Vdc	500Vdc
	MAX.PV Charging Current	60A	100A	100A	80A
	MAX.AC Charging Current	60A	60A	60A	60A
	MAX Charging Current	80A	100A	100A	100A
Display	LCD Display	Display Running Mode/Loads/Input/Output etc.			
Interface	RS232	Baud Rate2400			
	Communication Port	Lithium Battery BMS Communication Card WifiCard, Dry Contact			
	Parallel Connect Interface	Without Parallel Connect			
Environments	Operating Temperature	-10~50°C			
	Humidity	20%~95%(Non-condensing)			
	Storage Temperature	-15~60°C			
	Altitude	Altitude Not Over 1000m, Derating over 1000m, Max 4000m, Refer to IEC62040			
Noise	≤50db				

Table Of Contents

1 About This Manual	1
1.1 Purpose.....	1
1.2 Scope.....	1
2 Safety Instructions	1
3 Introduction	2
3.1 Features.....	2
3.2 Basic System Architecture.....	2
3.3 Product Overview.....	3
4 Installation	4
4.1 Unpacking And Inspection	4
4.2 Preparation	4
4.3 Mounting The Unit.....	5
4.4 Battery Connection.....	6
4.5 Ac Input/Output Connection.....	7
4.6 PV Connection.....	8
4.7 Final Assembly.....	10
4.8 Communication Connection	10
5 Operation	10
5.1 Power On/off.....	10
5.2 Operation and Display Pane	11
5.3 LCD Stting.....	20
5.4 Battery Equalization Description.....	25
5.5 Fantion and alarm description.....	27
6 Trouble removeal	29
7 Technical datasheet	30

6. Trouble removal

Problem	LCD/LED/Buzzer	Explanation/Possible cause	What to do
Unit shuts down automatically during startup process.	LCD/LEDs and buzzer will be active for 3 seconds and then complete off.	The battery voltage is too low (<1.91V/Cell)	1. Re-charge battery. 2. Replace battery.
No response after power on.	No indication	1. The battery voltage is far too low.<1.4V/Cell) 2. Internal fuse tripped.	1.Contact repair center for replacing the fuse. 2. Re-charge battery. 3. Replace battery.
Mains exist but the unit works in battery mode.	Input voltage is displayed as 0 on the LCD and green LED is flashing.	Input protector is tripped	Check if AC breaker is tripped and AC wiring is connected well.
	Green LED is flashing	Insufficient quality of AC power. (Shore or Generator)	1. Check if AC wires are too thin and/or too long. 2. Check if generator (if applied)is working well or if input voltage range setting is correct.(UP-->sppliance)
	Green LED is flashing.	Set "Solar First" as the priority of output source.	Change output source priority to Utility first.
When the unit is turned on, internal relay is switched on and off repeatedly.	LCD display and LEDs are flashing	Battery is disconnected.	Check if battery wires are connected well.
Buzzer beeps continuously and red LED is on.	Fault code 07	Overload error. The inverter is overload 105% and time is up.	Reduce the connected load by switching off some equipment.
		If PV input voltage is higher than specification, the output power will be derated. At this time, if connected loads is higher than derated output power, it will cause overload.	Reduce the number of PV modules in series or the connected load.
	Fault code 05	Output short circuited.	Check if wiring is connected well and remove abnormal load.
		Temperature internal converter component is over 120°C.	Check whether the air flow of the unit is blocked or whether the ambient temperature is too high.
	Fault code 02	Internal temperature of inverter component is over 100°C	Return to repair center.
	Fault code 03	Battery is over-charged	Return to repair center.
		The battery voltage is too high.	Check if spec and quantity of batteries are meet requirements.
	Fault code 01	Fan fault	Replace the fan.
	Fault code 06/58	Output abnormal (Inverter voltage below than 190Vac or is higher than 260Vac)	1. Reduce the connected load. 2. Return to repair center
	Fault code 08/09/53/57	Internal components failed.	Return to repair center.
	Fault code 51	Over current or surge.	Restart the unit, if the error happens again, please return to repair center.
Fault code 52	Bus voltage is too low.		
Fault code 55	Output voltage is unbalanced.		
Fault code 59	PV input voltage is beyond the specification.	Reduce the number of PV modules in series.	

5.5.2 Warning Descriptions

➤ **Alarm:** The red LED flashes, and the LCD displays an alarm code, the inverter does not enter the failure mode

Warning Indicator

Warning Code	Warning	Audible Alarm	Icon flashing
01	Fan is locked when inverter is on.	Beep three times every second	
02	Over temperature	None	
03	Battery is fully charged	Beep once every second	
04	Low battery	Beep once every second	
07	Overload	Beep once every 0.5 second	
10	Output power derating	Beep twice every 3 seconds	
15	PV energy is low.	Beep twice every 3 seconds	
16	High AC input (>280VAC) during BUS soft start	None	
	Battery equalization	None	
	Battery is not connected	None	

5.5.3 Code Reference

Related information code will be displayed on LCD screen. Please check inverter LCD screen for the operation.

Code	Description
60 ⚠	If battery status is not allowed to charge and discharge after the communication between the inverter and battery is successful, it will show code 60 to stop charging and discharging battery.
61 ⚠	Communication lost <ul style="list-style-type: none"> After battery is connected, communication signal is not detected for 3 minutes, buzzer will beep. After 10 minutes, inverter will stop charging and discharging to lithium battery. Communication lost occurs after the inverter and battery is connected successfully, buzzer beeps immediately.
69 ⚠	If battery status is not allowed to charge after the communication between the inverter and battery is successful, it will show code 69 to stop charging battery.
70 ⚠	If battery status must to charge after the communication between the inverter and battery is successful, it will show code 70 to charge battery.
71 ⚠	If battery status is not allowed to discharge after the communication between the inverter and battery is successful, it will show code 71 to stop discharge battery.

1 About This Manual

1.1 Purpose

This manual describes the assembly, installation, operation and troubleshooting of this unit. Please read this manual carefully before installations and operations, Keep manual for future reference.

1.2 Scope

This manual provides safety and installation guidelines as well as information on tools and wiring.

2 Safety Instructions



WARNING: This chapter contains important safety and operating instructions. Read and keep this manual for future reference.

- Before using the unit read all instructions and cautionary markings on the unit, the batteries and all appropriate sections of this manual.
- CAUTION-**To reduce risk of injury, charge only deep-cycle lead acid type rechargeable batteries. Other types of batteries may burst, causing personal injury and damage.
- Do not disassemble the unit Take it to a qualified service center when service or repair is required. Incorrect re-assembly may result in a risk of electric shock or fire.
- To reduce risk of electric shock, disconnect all wirings before attempting any maintenance or cleaning. Turning off the unit will not reduce this risk.
- CAUTION-**Only qualified personnel can install this device with battery.
- NEVER** charge a frozen battery.
- For optimum operation of this inverter/charger, please follow required spec to select appropriate cable size. It's very important to correctly operate this inverter/charger.
- Be very cautious when working with metal tools on or around batteries. A potential risk exists to drop a tool to spark or short circuit batteries or other electrical parts and could cause an explosion.
- Please strictly follow installation procedure when you want to disconnect AC or DC terminals, Please refer to INSTALLATION section of this manual for the details
- One piece of 150A fuse is provided as over-current protection for the battery supply.
- GROUNDING INSTRUCTIONS** -This inverter/ charger should be connected to a permanent grounder wiring system. Be sure to comply with local requirements and regulation to install this inverter.
- NEVER** cause AC output and DC input short circuited. Do NOT connect to the mains when DC input short circuits.
- Warning!!** Only qualified service persons are able to service this device. If errors still persist after following troubleshooting table, please send this inverter/charger back to local dealer or service center for maintenance.

3 Introduction

This is a multi-function Inverter/charger, combining functions of inverter, solar charger and battery charger to offer uninterruptible power support with portable size. Its comprehensive LCD display offers user-configurable and easy-accessible button operation such as battery charging current, AC/solar charger priority, and acceptable input voltage based on different applications.

3.1 Features

- ◆ Pure sine wave inverter
- ◆ Configurable input voltage range for home appliances and personal computers via LCD setting
- ◆ Configurable battery charging current based on applications via LCD setting
- ◆ Configurable AC/Solar Charger priority via LCD setting
- ◆ Compatible to mains voltage or generator power
- ◆ Auto restart while AC is recovering
- ◆ Overload/Over temperature/short circuit protection
- ◆ Smart battery charger design for optimized battery performance
- ◆ Cold start function

3.2 Basic System Architecture

The following illustration shows basic application for this inverter/charger. It also includes following devices to have a complete running system:

- ◆ Generator or Utility
- ◆ PV modules

Consult with your system integrator for other possible system architectures depending on your requirements.

This inverter can power all kinds of appliances in home or environment, including motor-type appliances such as tube light, fan, refrigerator and air conditioner.

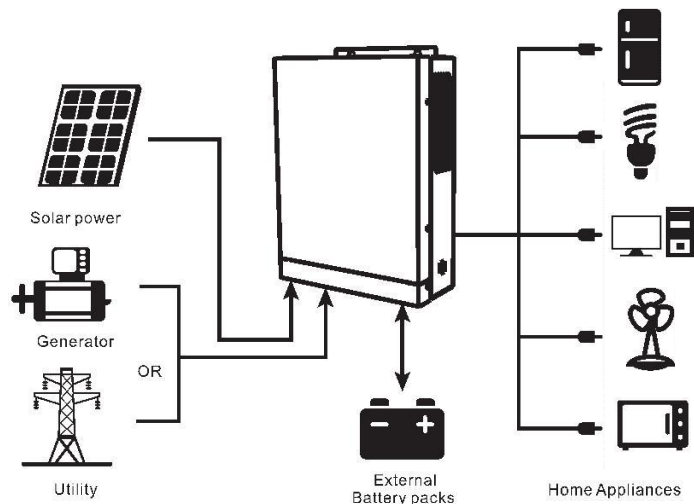

5.5 Function and alarm description

5.5.1 Faults Descriptions

➤ **Fault:** The inverter enters the fault mode, the red LED light is always on and the LCD displays the fault code.

Fault Reference Code

Fault Code	Fault Event	Icon on
01	Fan is blocked when inverter is off.	
02	Over temperature or NTC is not connected well.	
03	Battery voltage is too high.	
04	Battery voltage is too low.	
05	Output short circuited or over temperature is detected by internal converter components.	
06	Output voltage is too high.	
07	Over load time out.	
08	Bus voltage is too high	
09	Bus soft start failed	
51	Over currents or surge	
52	Bus voltage is too low	
53	Inverter soft start failed	
55	Over DC voltage in AC output	
57	Current sensor failed	
58	Output voltage is too low	
59	PV voltage is over limitation	

※ When to Equalize

In stage, when the setting equalization interval(battery equalization cycle) is arrived, or equalization is active immediately, the controller will start to enter Equalize stage.

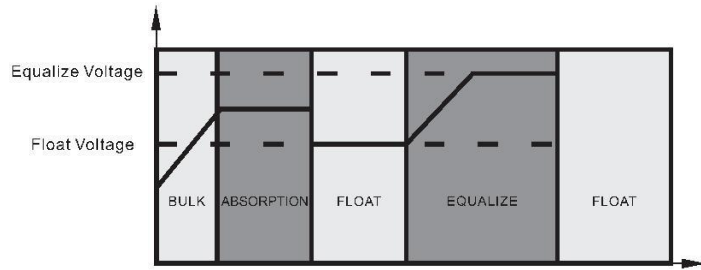

※ Equalize charging time and timeout

In Equalize stage, the controller will supply power to charge battery as much as possible until battery voltage raises to battery equalization voltage. Then, constant-voltage regulation is applied to maintain battery voltage at the battery equalization voltage. The battery will remain in the Equalize stage until setting battery equalized time is arrived.

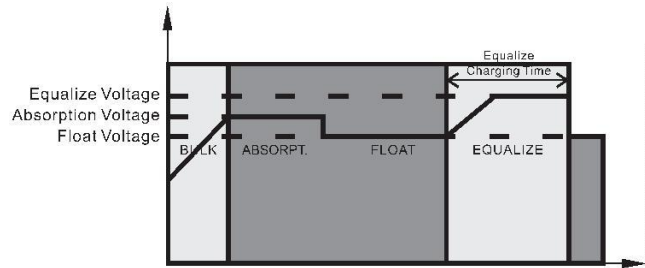

However, in Equalize stage, when battery equalized time is expired and battery voltage doesn't rise to battery equalization voltage point, the charge controller will extend the battery equalized time until battery voltage achieves battery equalization voltage. If battery voltage is still lower than battery equalization voltage when battery equalized timeout setting is over, the charge controller will stop equalization and return to float stage.

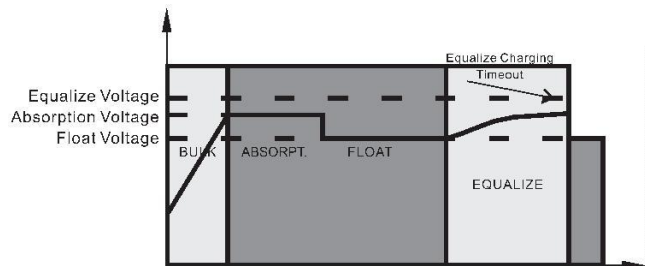

3.3 Product Overview

3.3.1 Back Panel

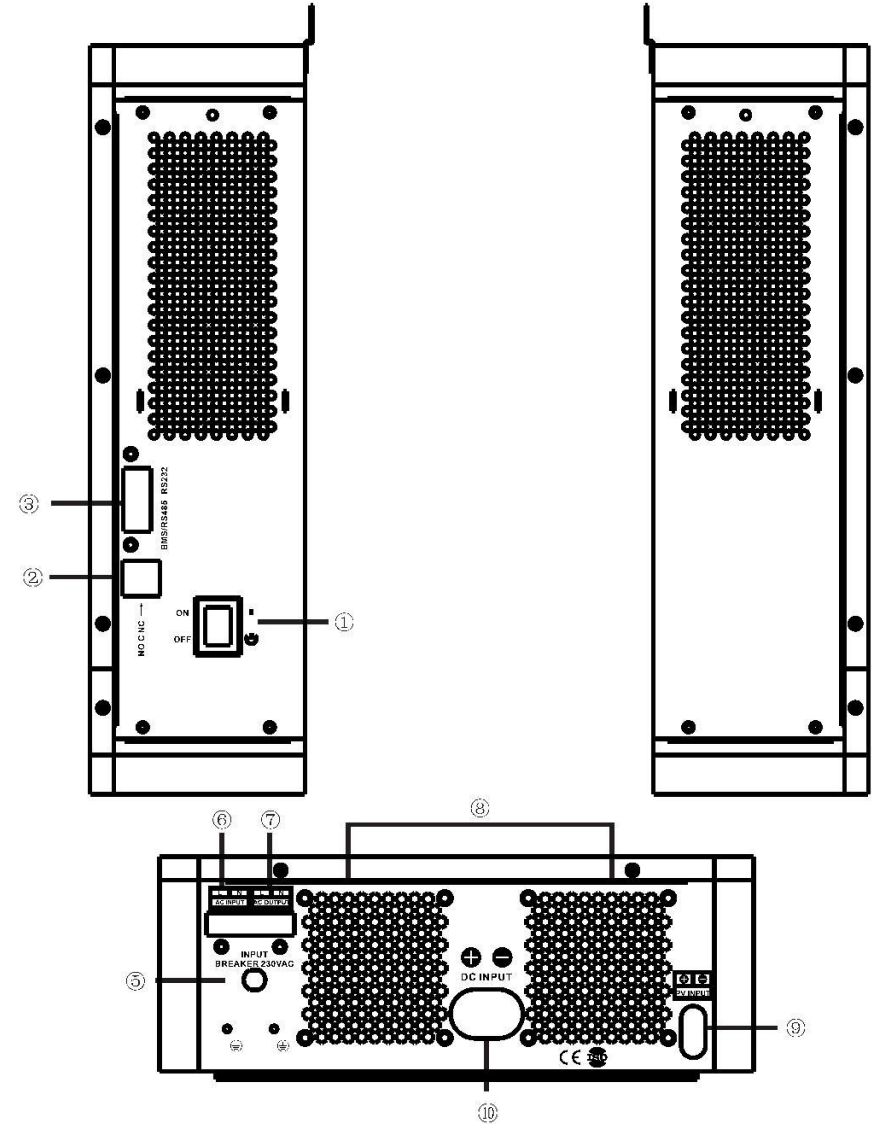

- | | |
|----------------------------------|-------------------|
| 1..Power ON/ OFF Switch | 6. AC Input |
| 2..Dry Contact | 7.. AC Output |
| 3...BMS/RS485 Communication Port | 8.. Fan |
| 4...RS232 Communication Port | 9..PV Input |
| 5..Input Breaker | 10. Battery Input |

3.3.2 LCD Screen

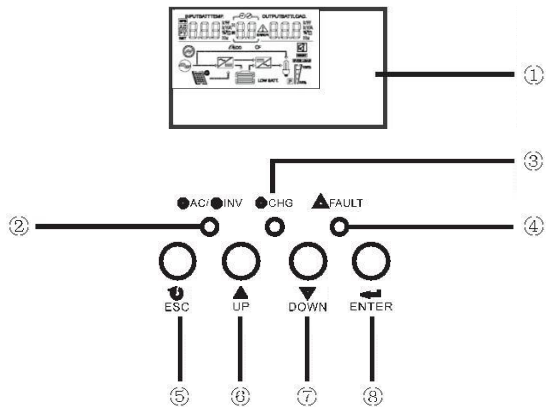

- | | |
|--------------------------|-------------|
| 1.....LCD display | 5.....ESC |
| 2.....Status indicator | 6.....UP |
| 3.....Charging indicator | 7.....DOWN |
| 4.....Fault indicator | 8.....ENTER |

4 INSTALLATION

4.1 Unpacking and Inspection

Before installation, please inspect the unit. Be sure that nothing inside the package is damaged. You should have received the following items inside of package:

- ◆ The unit x 1
- ◆ User manual 1

4.2 Preparation

Before connecting all please take off bottom cover by removing two screws as shown below.

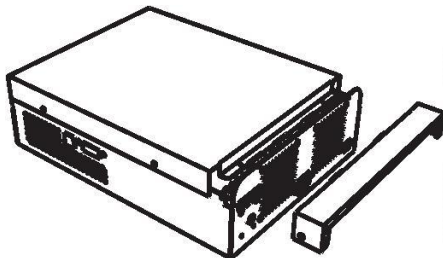

38	Bat Soc Under Lock	b5U 38 BATT 10%	BMS low voltage SOC value, if the BMS SOC value is lower than the set value, the inverter will shut down to protect the battery.
39	Bat Soc Turn To Ac	5t0 39 BATT 20%	When the working mode of the inverter is set to the battery priority mode, the inverter will be forced to enter the mains charging when the SOC of the BMS is lower than the set value.
40	Bat Soc Turn To Dc	5t6 40 BATT 95%	When the working mode of the inverter is set to the battery priority mode, the inverter resumes the DC working mode when the SOC of the BMS is higher than the set value.
41	Bat Restart Soc	b5t 41 BATT 50%	When the inverter is turned on, the SOC must be higher than the set value to work normally.

When the BMS/485 communication interface is externally connected, as shown in the following figure:

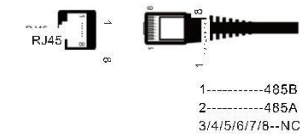

5.4 Battery Equalization Description

Equalization function is added into charge controller, It reverses the buildup of negative chemical effects like stratification, a condition where acid concentration is greater at the bottom of the battery than at the top. Equalization also helps to remove sulfate crystals that might have built up on the plates. If left unchecked, this condition, called sulfation, will reduce the overall capacity of the battery. Therefore, it's recommended to equalize battery periodically.

※ How to Apply Equalization Function

You must enable battery equalization function in monitoring LCD setting program 30 first. Then, you may apply this function in device by either one of following methods:

1. Setting equalization interval in program 35.
2. Active equalization immediately in program 36.

30	Battery equalization 30 E30 EdS EV 31 29.2	Battery equalization	Battery equalization disable (default)
		If "Flooded" or "User Defined" is selected in program05, this program can be set up.	
31	Battery Equalization voltage 33 60 34 120 35 30d EV 31 146	12V system default setting:14.6V	
		24V system default setting:29.2V	
		Setting range is from12.5V to15.5V for 12V system mode and 25.0V to 31.5V for 24V system mode Increment of each click is 0.1V.	
33	Battery equalized time	60min (default)	Setting range is from 5min to 900min. Increment of each click is 5min.
34	Battery equalized timeout	120min (default)	Setting range is from 5min to 900min. Increment of each click is 5min.
35	Equalization interval	30days (default)	Setting range is from 0 to 90 days. Increment of each click is 1 day.
36	Equalization activated immediately	Enable	Disable (default)
		If equalization function is enabled in program 30, this program can be set up. If "Enable" is selected in this program, it's to activate battery equalization immediately and LCD main page will shows " ", If "Disable" is selected, it will cancel equalization function until next activated equalization time arrives based on program 35 setting. At this time, " " will not be shown in LCD main page.	
37	BMS Function Switch	off(default)	Whether to enable the BMS communication function
		bns 37 OFF bns 37 ON	

4.3 Mounting the Unit

Consider the following points before selecting where to install:

- ※ Do not mount the inverter on flammable construction materials.
- ※ Mount on a solid surface
- ※ Install this inverter at eye level in order to allow the LCD display to be read at all times.
- ※ For proper air circulation to dissipate heat, allow a clearance of approx. 20 cm to the side and approx. 50 cm above and below the unit.
- ※ The ambient temperature should be between and to ensure optimal operation.
- ※ The recommended installation position is to be adhered to the wall vertically.
- ※ Be sure to keep other objects and surfaces as shown in the diagram to guarantee sufficient heat dissipation and to have enough space for removing wires.

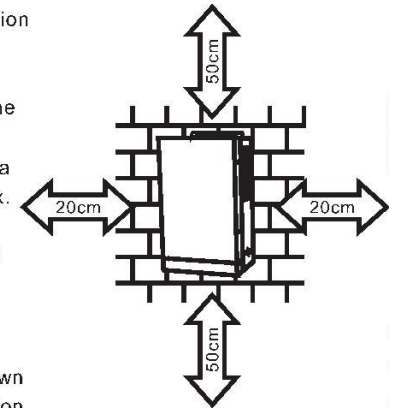

▲ SUITABLE FOR MOUNTING ON CONCRETE OR OTHER NON-COMBUSTIBLE SURFACE ONLY.

Install the unit by screwing two screws.

- 1,2 Use the M6*80mm expansion bolts.

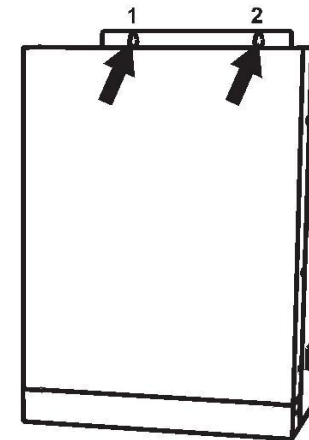

4.4 Battery Connection

CAUTION: For safety operation and regulation compliance, it's requested to install a separate DC over-current protector or disconnect device between battery and inverter. It may not be requested to have a disconnect device in some applications, however, it's still requested to over-current protection installed. Please refer to typical amperage in below table as required fuse or breaker size.

WARNING! All wiring must be performed by be qualified personnel.
WARNING! It's very important for system safety and efficient operation to use appropriate cable for battery connection. To reduce risk of injury, please use the proper recommended cable and terminal size as below.

Ring terminal:



Recommended battery cable and terminal size:

Rated Capacity	Typical Amperage	Battery capacity	Wire Size	Ring Terminal			Torque value
				Cable(mm ²)	Dimensions		
					D(mm)	L(mm)	
1KVA/2KVA	44A/88A	100AH	1*6AWG	14	6.4	33.2	2~3 Nm
			2*10AWG	6	6.4	23.8	
3KVA	132A	100AH	1*4AWG	22	6.4	33.2	2~3 Nm
		200AH	2*8AWG	9	6.4	29.2	
5KVA	109A	200AH	1*2AWG	38	6.4	39.2	2~3 Nm
			2*6AWG	28	6.4	33.2	

please follow below steps to implement battery connection:

1. Assemble battery ring terminal based on recommended battery cable and terminal size.

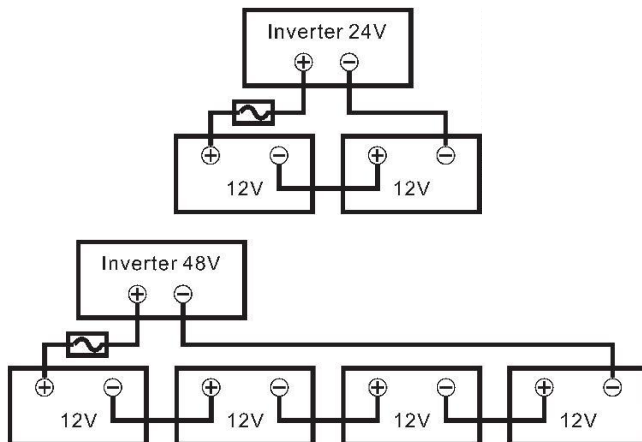

23		Bypass disable (default)	Bypass enable
25		Record enable (default)	Record disable
26		12V system default setting: 14.1 V	
27		If self-defined is selected in program 5, this program can be set up. Setting range is from 12.5V to 15.5V for 12V system model and 25.0V to 31.5V for 24V system model. Increment of each click is 0.1V.	
		12V system default setting: 13.5 V	
28		24V system default setting: 27.0 V	
		default:	
29			
		If self-defined is selected in program 5, this program can be set up. Setting range is from 10.5V to 12V for 12V system model and 21.0V to 24.0V for 24V system model. Increment of each click is 0.1V. Low DC cut-off voltage will be fixed to setting value no matter what percentage of load is connected.	
		24V system default setting: 21.0 V	

	13 F13 270 ^V 16 CUE 16 C50	Available options in 24V system model:	
		Battery fully charged	27V(default)
		Setting range is from 24V to 29V. Increment of each click is 0.5V.	
16	16 SHU 16 OSO 18 61 18 BOF 18 ESP 20 FEP 22 L20 LOF 22 A22 ROF Charger source priority: To configure charger source priority	If this inverter/charger is working in Line, Standby or Fault mode, charger source can be programmed as below:	
		Utility first	Utility will charge battery as first priority. Solar energy will charge battery only when utility power is not available.
		Solar first	Solar energy will charge battery as first priority. Utility will charge battery only when solar energy is not available.
		Solar and Utility(default)	Solar energy and utility will charge battery at the same time.
		Only Solar	Solar energy will be the only charger source no matter utility is available or not.
		If this inverter/charger is working in Battery mode, only solar energy can charge battery. Solar energy will charge battery if it's available and sufficient.	
18	Alarm control	Alarm on (default)	Alarm off
19	Auto return to default display screen	Return to default display screen (default)	If selected, no matter how users switch display screen, it will automatically return to default display screen (Input voltage /output voltage) after no button is pressed for 1 minute.
		Stay at latest screen	If selected, the display screen will stay at latest screen user finally switches.
20	Backlight control	Backlight on (default)	Backlight off
22	Beeps while primary source is interrupted	Alarm on (default)	Alarm off

2. Insert the battery wires flatly into battery connectors of inverter and make sure the bolts are tightened with torque of 2 Nm in clockwise direction. Make sure polarity at both the battery and the inverter/charge is correctly connected and conductors are tightly screwed into the battery terminals. Recommended tool: # 2 Pozi Screwdriver

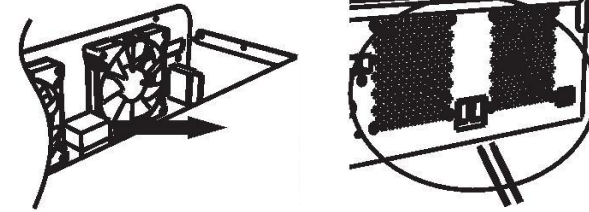

	WARNING: Shock Hazard Installation must be performed with care due to high battery voltage in series.
	CAUTION!! Before making the final DC connection or closing DC breaker/disconnector, be sure positive (+) must be connected to positive (+) and negative (-) must be connected to negative (-).

4.5 AC Input Output Connection

CAUTION!! Before connecting to AC input power source, please install a separate AC breaker between inverter and AC input power source. This will ensure the inverter can be disconnected during maintenance and fully protected from over current of AC input. The recommended spec of breaker is 25 A for 12V system and breaker is 32A for 24V system.

CAUTION!! There are two terminal blocks with " IN " and " OUT " markings. Please do NOT mis-connect input and output connectors.

WARNING! All wiring must be performed by qualified personnel.

WARNING! It's very important for system safety and efficient operation to use appropriate cable for AC input connection. To reduce risk of injury, please use the proper recommended cable size as below.

Suggested cable requirement for AC wires

Rated Capacity	Gauge	Torque value
1KVA	16AWG	0.5~0.6Nm
2KVA	14AWG	0.8~1.0Nm
3KVA	12AWG	1.2~1.6Nm
5KVA	8AWG	1.4~1.6Nm

Please follow below steps to implement AC input/ output connection

1. Before making AC input/output connection be sure to open DC protector or disconnect first.
2. Remove insulation sleeve 10mm for six conductors. And shorten phase L and neutral conductor N3 mm.

3. Insert AC input wires according to polarities indicated on terminal block and tighten the terminal screws. Be sure to connect PE protective conductor(⚡) first.

- ⚡→Ground(yellow-green)
- L→LINE(brown or black)
- N→Neutral (blue)

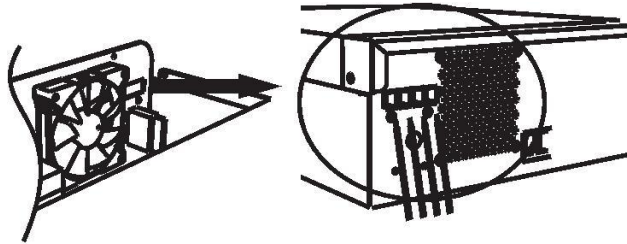

WARNING: Be sure that AC power source is disconnected before attempting to hardwire it to the unit.

4. Make sure the wires are securely connected

CAUTION: Appliances such as air conditioner are required at least 2~3 minutes to restart because it's required to have enough time to balance refrigerant gas inside of circuits. If a power shortage occurs and recovers in a short time, it will cause damage to your connected appliances. To prevent this kind of damage, please check manufacturer of air conditioner if it's equipped with time-delay function before installation. Otherwise, this inverter/ charger will trig overload fault and cut off output to protect your appliance but sometimes it still causes internal damage to the air conditioner.

4.6 PV Connection

PV Connection(Only apply for the model with solar charger)

CAUTION:Before connecting to PV modules, please install **separately** a DC circuit breaker between inverter and PV modules.

WARNING! All wiring must be performed by a qualified personnel.

WARNING! It's very important for system safety and efficient operation to use appropriate cable for PV module connection. To reduce risk of injury, please use the proper recommended cable size as below.

Typical Amperage	Gauge	Torque Value
10A	12AWG	1.4~1.6Nm

PV module selection:

When choosing the right PV module, be sure to first consider the following requirements:

The open circuit voltage (Voc) of the PV modules does not exceed the maximum PV array open circuit voltage of the inverter. The maximum supply voltage of the PV modules should be close to the optimal PV access voltage range of the inverter for best performance. If one PV module cannot meet this requirement, it is necessary to connect multiple PV modules in series.

06		Restart disable(default)	Restart enable
07		Restart disable (default)	Restart enable
08		disable (default)	
		enable	
09		50Hz(default)	60Hz
10	Output voltage	220V	230V (default)
		240V	
11	Maximum utility charging current Note: If setting value in program 02 is smaller than that in program in 11, the inverter will apply charging current from program 02 for utility charger.	30A(default)	Setting range is 2A, then from 10A to max.AC charging current. Increment of each click is 10A.
12	Setting voltage point back to utility source when selecting"SBU priority" in program 01.	Available options in 12V system model:	
		11.5V (default)	Setting range is from 11 V to 12.5V. Increment of each click is 0.5V.
Available options in 24V system model:			
		23.0V (default)	Setting range is from 22V to 25.5V. Increment of each click is 0.5V.
13	Setting voltage point back to battery mode when selecting"SBU priority" in program 01.	Available options in 12V system model:	
		Battery fully charged	13.5V (default)
		Setting range is from 12V to 14.5V. Increment of each click is 0.5V.	

5.3 LCD Setting

After pressing and holding ENTER button for 3 seconds, the unit will enter setting mode. Press "UP" or "DOWN" button to select setting programs. And then, press "ENTER" button to confirm the selection or ESC button exit.

Setting Programs:

Program	Description	Selectable option	
00	ESC Exit setting mode	Escape	
01	02 60 03 API 03 UPS 05 AOS FLD 05 USE load power source priority	Utility first (default) 01 USB	Utility will provide power to the loads as first priority. Solar and battery energy will provide power to the loads only when utility power is not available.
		Solar first 01 SUB	Solar energy provides power to the loads as first priority. If solar energy is not sufficient to power all connected loads, Utility energy will supply power to the loads at the same time.
		BU priority 01 SUBU	Solar energy provides power to the loads as first priority. If solar energy is not sufficient to power all connected loads, battery energy will supply power to the loads at the same time. Utility provides power to the loads only when battery voltage drops to either low-level warning voltage or the setting point in program 12.
02	Maximum charging current. To configure total charging current for solar and utility chargers. (Max. charging current = utility charging current + solar charging current)	60A(default)	Setting range is from 10A to maximum charging current. Increment of each click is 10A.
03	AC input voltage range	Appliances (default)	If selected, acceptable AC input voltage range will be within 90-280VAC.
		UPS	If selected, acceptable AC input voltage range will be within 170-280VAC.
05	Battery type	AGM (default)	Flooded
		User-Defined	If "User-Defined" is selected, battery charge voltage and low DC cut-off voltage can be set up in program 26, 27 and 29.

Model	1012EMH	2012EMH	3024EMH	5048EMH
PV Charging mode	MPPT	MPPT	MPPT	MPPT
MAX. PV Input power	1000W	1600W	3000W	5000W
MPPT Tracking range	30~450Vdc	40~500Vdc	40~500Vdc	40~500Vdc
MAX. PV Input Voltage	300~400Vdc	300~400Vdc	300~400Vdc	300~400Vdc
Best voltage	400Vdc	500Vdc	500Vdc	500Vdc
MAX. PV Charging current	60A	100A	100A	80A
MAX. AC Charging current	60A	60A	60A	60A
MAX. Charging current	80A	100A	100A	100A

PV Module Wire Connection

Please follow below steps to implement PV module connection:

1. Remove insulation sleeve 10 mm for positive and negative conductors.
2. Suggest to put bootlace ferrules on the end of positive and negative wires with a proper crimping tool
3. Fix wire cover to the inverter with supplied screws as shown in below chart.

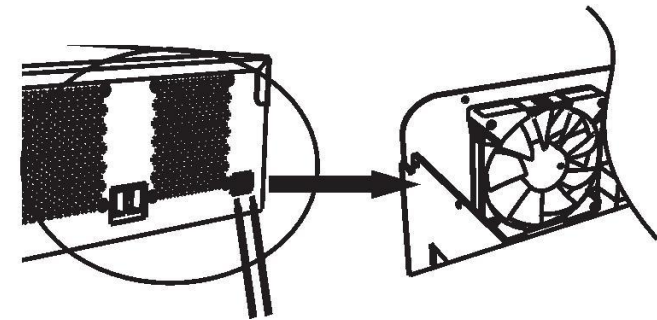
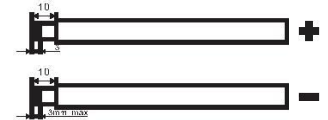

4. Check correct polarity of wire from PV modules and PV input connectors. Then, connect positive pole (+) of connection wire to positive pole (+) of PV input connector. Connect negative pole (-) of connection wire to negative pole (-) of PV input connector. Screw two wires tightly in clockwise direction. Recommended tool: 4mm blade screwdriver.

4.7 Final Assembly

After connecting all wirings, please put bottom cover back by screwing two screws as shown below.



5 OPERATION

5.1 Power ON/OFF

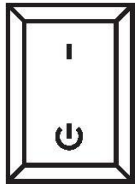

Once the unit has been properly installed and the batteries are connected well, simply press On/Off switch (located on the button of the case) to turn on the unit.

5.1.1 Steps to start up

Connect the battery that meets the requirements (battery voltage needs to be beyond 23V) or AC (AC needs to confirm the suitable input range depend on the output mode), then you can start up the inverter.

➤ Mains power on

Connect to normal AC power, press the switch, the system will automatically turn on. If you set AC output power priority, after waiting for a period of time, the panel will display AC mode that represents turn on the machine successfully, then will enter the AC mode.

➤ Battery boot

Connect to battery, press the power-on button to establish a working power source.

The system will automatically turn on, after waiting for a period of time, the panel will display battery mode that represents turn on the machine successfully, then will enter the battery mode.

5.1.2 Shutdown steps

When the system is in battery mode or AC mode output, press the switch again, then the system will be turned off.

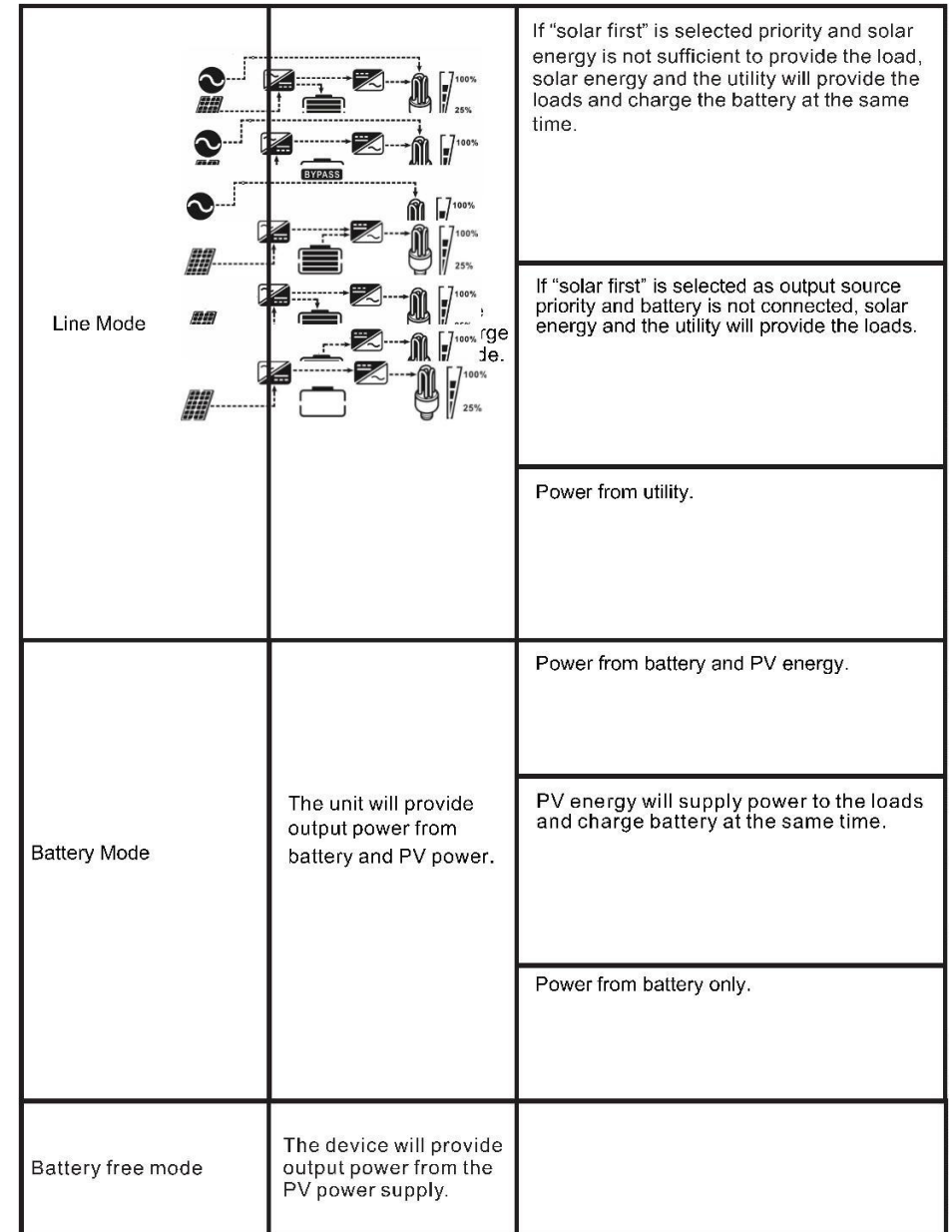

Operating Mode Description

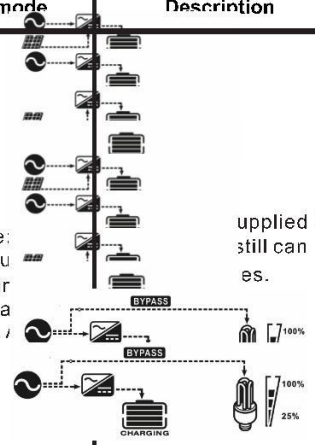
Operation mode	Description	LCD display
Standby mode Note: *Standby mode: inverter is not turning yet but at this time inverter can charge battery without output.	 applied by utility still can charge.	Charging by utility and PV energy.
		Charging by utility
		Charging by PV energy.
		No charging
Fault mode Note: *Fault mode: Errors are caused by inside circuit error or external reasons such as over temperature, output short circuited and so on.	PV energy and utility can charge batteries.	Charging by utility and PV energy.
		Charging by utility
		Charging by PV energy.
		No charging.
Line Mode	The unit will provide output power from the mains. It will also charge the battery at line mode.	Charging by utility and PV energy.
		Charging by utility.

5.2 Operation and Display Panel

The operation and display panel, shown in below chart, is on the front panel of the inverter. It includes three indicators, four function keys and a LCD display, indicating the operating status and input/output power information.



LCD display

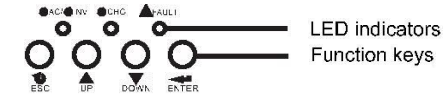

LED indicators

Function keys

LED Indicator

LED Indicator	LED Indicator	Messages	
● AC/● INV ● CHG ▲ FAULT	Green	Solid On	Output is powered by utility in Line mode.
		Flashing	Output is powered by battery or PV in battery mode.
	Green	Solid On	Battery is fully charged.
		Flashing	Battery is charging.
	Red	Solid On	Fault occurs in the inverter.
		Flashing	Warning condition occurs in the inverter.

Function Keys

Function Key	Description
ESC	To exit setting mode
UP	To go to previous selection
DOWN	To go to next selection
ENTER	To confirm the selection in setting mode or enter setting mode

LCD Display Icons

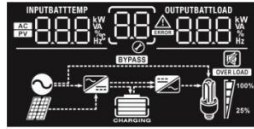







Icon	Function description
Input Source Information	
	Indicates the AC input.
	Indicates the PV input.
	Indicate input voltage, input frequency, PV voltage, charger current, charger power, battery voltage.
Setting Program and Fault Information	
	Indicates the setting programs.
	Indicates the warning and fault codes.
	Warning: flashing with warning code
	Fault: lighting with fault code
Output Information	
	Indicate output voltage, output frequency, load percent, load in VA, load in Watt and discharging current.
Battery Information	
	Indicates battery level by 0-24%, 25-49%, 50-74% and 75-100% in battery mode and charging status in line mode.

 Load in Watt 	<p>When load is lower than 1kW, load in W will present xxxW like below chart.</p> <p>When load is larger than 1kW($\geq 1kW$), load in W will present x.xkW like below chart.</p>
Battery voltage/DC discharging current	Battery voltage=25.5V, discharging current=1A
Main CPU version checking	Main CPU version 00014.04
Setting BMS communication success display	<p>The left side shows the lithium battery temperature and the right side shows the lithium battery capacity.</p> <p>The input current of the lithium battery is displayed on the left side, and the output current of the lithium battery is displayed on the right side.</p>



	Battery voltage =25.5V, output voltage=230V
	Output frequency=50Hz
	Load percent=70%
	<p>When connected load is lower than 1kVA, load in VA will present xxxVA like below chart.</p> <p>When load is larger than 1kVA(≥ 1KVA), load in VA will present x.xkVA like below chart.</p>





In AC mode, it will present battery charging status.																					
<table border="1"> <thead> <tr> <th>Status</th> <th>Battery voltage</th> <th>LCD Display</th> </tr> </thead> <tbody> <tr> <td>Constant</td> <td><2V/cell</td> <td>4 bars will flash in turns.</td> </tr> <tr> <td>Current mode/</td> <td>2.167V/cell</td> <td>Bottom bar will be on and the other three bars will flash in turns.</td> </tr> <tr> <td>Constant</td> <td>2.167V/cell</td> <td>Bottom two bars will be on and the other two bars will flash in turns.</td> </tr> <tr> <td>Voltage mode</td> <td>>2.167V/cell</td> <td>Bottom three bars will be on and the top bar will flash.</td> </tr> <tr> <td>Floating mode. Batt</td> <td>fully charged.</td> <td>4 bars will be on.</td> </tr> </tbody> </table>	Status	Battery voltage	LCD Display	Constant	<2V/cell	4 bars will flash in turns.	Current mode/	2.167V/cell	Bottom bar will be on and the other three bars will flash in turns.	Constant	2.167V/cell	Bottom two bars will be on and the other two bars will flash in turns.	Voltage mode	>2.167V/cell	Bottom three bars will be on and the top bar will flash.	Floating mode. Batt	fully charged.	4 bars will be on.			
Status	Battery voltage	LCD Display																			
Constant	<2V/cell	4 bars will flash in turns.																			
Current mode/	2.167V/cell	Bottom bar will be on and the other three bars will flash in turns.																			
Constant	2.167V/cell	Bottom two bars will be on and the other two bars will flash in turns.																			
Voltage mode	>2.167V/cell	Bottom three bars will be on and the top bar will flash.																			
Floating mode. Batt	fully charged.	4 bars will be on.																			
In AC mode, it will present battery capacity.																					
	<table border="1"> <thead> <tr> <th>Battery Voltage</th> <th>LCD Display</th> </tr> </thead> <tbody> <tr> <td>< 1.892V/cell</td> <td></td> </tr> <tr> <td>1.892V/cell~1.975V/cell</td> <td></td> </tr> <tr> <td>1.975V/cell~2.058V/cell</td> <td></td> </tr> <tr> <td>>2.058V/cell</td> <td></td> </tr> </tbody> </table>	Battery Voltage	LCD Display	< 1.892V/cell		1.892V/cell~1.975V/cell		1.975V/cell~2.058V/cell		>2.058V/cell											
Battery Voltage	LCD Display																				
< 1.892V/cell																					
1.892V/cell~1.975V/cell																					
1.975V/cell~2.058V/cell																					
>2.058V/cell																					
Load Information																					
Indicates overload.																					
Indicates the load level by 0-24%, 25-49%, 50-74% and 75-100%.																					
0%~24%	25%~49%	50%~74%	75%~100%																		

M Operation Information	
	Indicates unit connects to the mains.
	Indicates unit connects to the PV panel
	Indicates load is supplied by utility power
	Indicates the utility charger circuit is working.
	Indicates the DC/AC inverter circuit is working.
Mute Operation	
	Indicates unit alarm is disabled.

Display Setting

The LCD display information will be switched in turns by pressing "UP" or "DOWN" key. The selectable information is switched as below order input voltage, input frequency, PV voltage, charging current, charging power battery voltage, output voltage, output frequency, load percentage, load in Watt, load in VA, load in Watt, DC discharging current, main CPU Version.

Selectable information	LCD display
 Input voltage (Default Display)	Input Voltage=230V, output voltage=230V
 Input frequency	Input frequency =50Hz
 PV voltage	PV voltage=260V

	PV current = 2.5A
 PV power	PV power = 500W
 Charging current	AC and PV charging current=50A PV charging current=50A AC charging current=50A
 Charging power	AC and PV charging power=500W PV charging power=500W AC charging power=500W