

Product Type

POW-LVM3K-24V-H

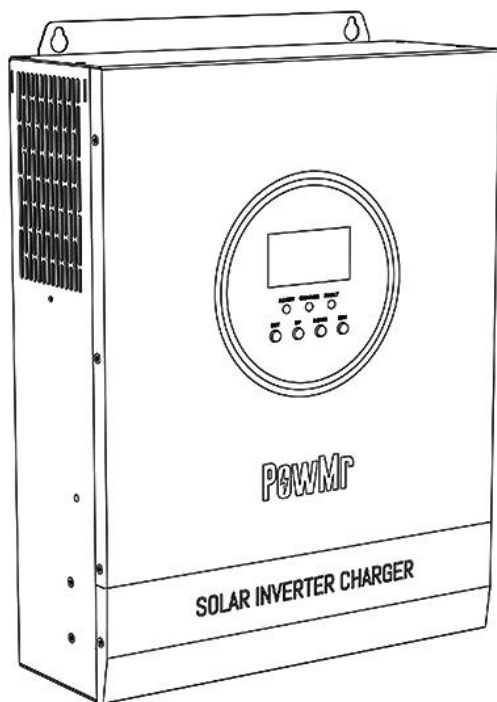

# POWMr

HYBRID INVERTER

User Manual

# Important Safety Instructions

---

Please save these instructions for future use!

This manual contains all safety, installation and operating instructions for the POW-LVM3K Series all-in-one solar charge inverter.

**Please read all instructions and precautions in the manual carefully before installation and use.**

- Non-safety voltage exists inside the all-in-one solar charge inverter. To avoid personal injury, users shall not disassemble the all-in-one solar charge inverter themselves. Contact our professional maintenance personnel if there is a need for repair.
- Do not place the all-in-one solar charge inverter within the reach of children.
- Do not install the all-in-one solar charge inverter in harsh environments such as moist, oily, flammable or explosive, or heavily dusty areas.
- The mains input and AC output are high voltage, so please do not touch the wiring terminals.
- The housing of the all-in-one solar charge inverter is hot when it is working. Do not touch it.
- Do not open the terminal protective cover when the all-in-one solar charge inverter is working.
- It is recommended to attach proper fuse or circuit breaker to the outside of the all-in-one solar charge inverter.
- Always disconnect the fuse or circuit breaker near the terminals of PV array, mains and battery before installing and adjusting the wiring of the all-in-one solar charge inverter.
- After installation, check that all wire connections are tight to avoid heat accumulation due to poor connection, which is dangerous.
- The all-in-one solar charge inverter is off-grid. It is necessary to confirm that it is the only input device for load, and it is forbidden to use it in parallel with other input AC power to avoid damage.

# Table of Contents

<b>Important Safety Instructions</b> .....	<b>1</b>
<b>Production Instructions</b> .....	<b>4</b>
Features .....	5
Basic System Introduction.....	6
Production Overview.....	7
Dimension Drawing.....	8
<b>Installation</b> .....	<b>9</b>
Installation Notice .....	9
Select the Mount Location.....	10
Mount the Inverter.....	10
Preparation.....	11
<b>Connection</b> .....	<b>12</b>
Wiring Specification and Breaker Type.....	12
AC Input/Output Wiring .....	13
PV Input Wiring.....	14
Battery Wiring.....	15
Final Assembly.....	16
Start Up the Inverter .....	16
<b>Operation Mode</b> .....	<b>17</b>
Charging Mode .....	17
Output Mode.....	20
<b>Operation Instruction</b> .....	<b>21</b>
Operation and Display Panel .....	21
Introduction to LCD Screen.....	22
Real-time Data Viewing Method.....	24
Setting Parameter.....	25
Battery Type Parameters .....	35
<b>Other Functions</b> .....	<b>37</b>
Dry Node .....	37
RS485 Communication Port.....	37

CAN Communication Function ..... 37

USB communication port ..... 37

**Protection ..... 38**

    Protections Provided ..... 38

    Fault Code Meaning ..... 40

    Troubleshooting ..... 42

**System maintenance ..... 43**

**Technical parameters ..... 44**

# Production Instructions

POW-LVM3K series is a new all-in-one hybrid solar charge inverter, which integrates solar energy storage, mains charging energy storage, and AC sine wave output. Thanks to DSP control and an advanced control algorithm, it offers high response speed, high reliability, and high industrial standards. Two charging modes are optional, i.e. Only Solar and Mains & Solar hybrid charging, and four output modes are available, i.e. PV priority, Mains priority, Inverter priority, and Mixed mode, to meet different application requirements.

The solar charging module applies the latest optimized MPPT technology to quickly track the maximum power point of the PV array in any environment and obtain the maximum energy of the solar panel in real time.

Through a state of the art control algorithm, the AC-DC charging module realizes fully digital voltage and current double closed loop control, with high control precision in a small volume. Wide AC voltage input range and complete input/output protections are designed for stable and reliable battery charging and protection.

Based on full-digital intelligent design, the DC-AC inverter module employs advanced SPWM technology and outputs pure sine wave to convert DC into AC. It is ideal for AC loads such as household appliances, power tools, industrial equipment, and electronic audio and video equipment. The product comes with a segment LCD display design which allows real-time display of the operating data and status of the system. Comprehensive electronic protections keep the entire system safer and more stable.

## ■ Features

- Full digital voltage and current double closed loop control, advanced SPWM technology, output of pure sine wave.
- Four output modes: PV priority, Main priority, Inverter priority, Mixed mode.
- Available in 2 charging modes: Only Solar, Mains and Solar hybrid charging.
- Advanced MPPT technology with an efficiency of 99.9%.
- Designed with a LCD screen and 3 LED indicators for dynamic display of system data and operating status.
- ON/OFF rocker switch for AC output control.
- Power saving mode available to reduce no-load loss.
- Intelligent variable speed fan to efficiently dissipate heat and extend system life.
- Lithium battery activation by PV solar or mains, allowing access of lead-acid battery and lithium battery.
- 360 ° all-round protection with a number of protection functions.
- Complete protections, including short circuit protection, over voltage and under voltage protection, overload protection, reverse protection, etc.

## ■ Basic System Introduction

The figure below shows the system application scenario of this product. A complete system consists of the following parts:

1. **PV module:** Convert light energy into DC power, and charge the battery through the all-in-one solar charge inverter, or directly invert into AC power to drive the load.
2. **Mains or generator:** Connected at the AC input, to power the load while charging the battery. If the mains or generator is not connected, the system can also operate normally, and the load is powered by the battery and PV module.
3. **Battery:** Provided to ensure normal power supply to the system loads when solar energy is insufficient and the Mains is not connected.
4. **Household load:** Allow connection of various household and office loads, including refrigerators, lamps, TVs, fans and air conditioners.
5. **All-in-one solar charge inverter:** The energy conversion unit of the whole system.

Specific system wiring method depends on the actual application scenario.

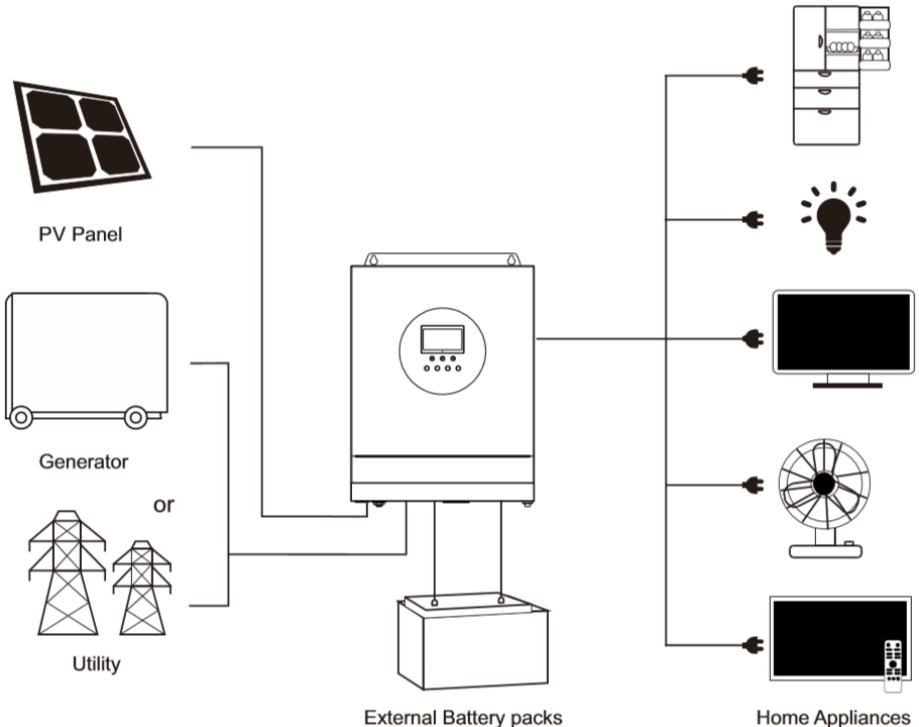

## ■ Production Overview

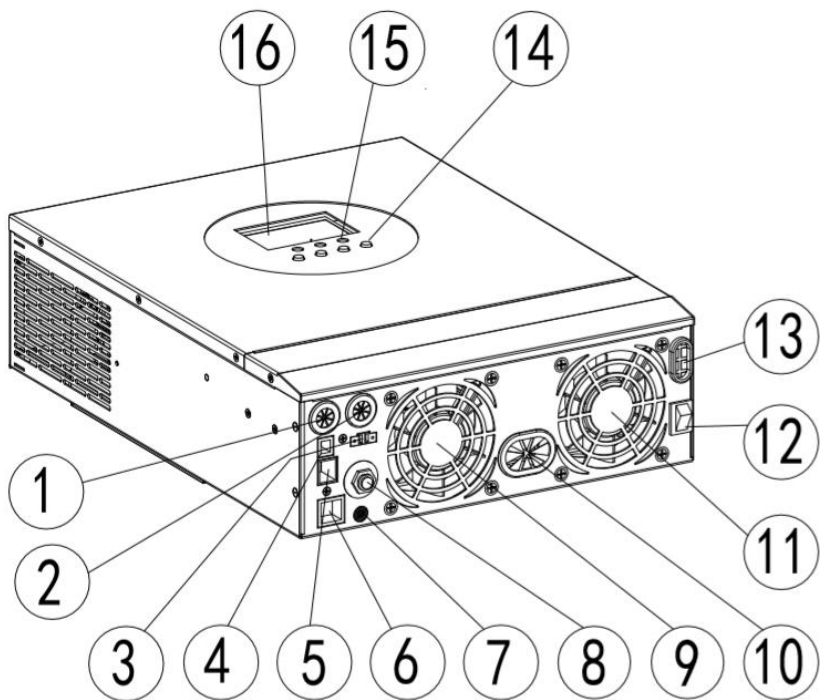

①	AC input port	⑨	Cooling fan
②	AC output port	⑩	Battery port
③	CAN communication port	⑪	Cooling fan
④	USB communication port	⑫	ON/OFF rocker switch
⑤	RS485 communication port	⑬	PV port
⑥	Dry contact port	⑭	Touch the key lightly
⑦	Grounding screw hole	⑮	LED Indicator
⑧	Overload protector	⑯	LCD screen

## ■ Dimension Drawing

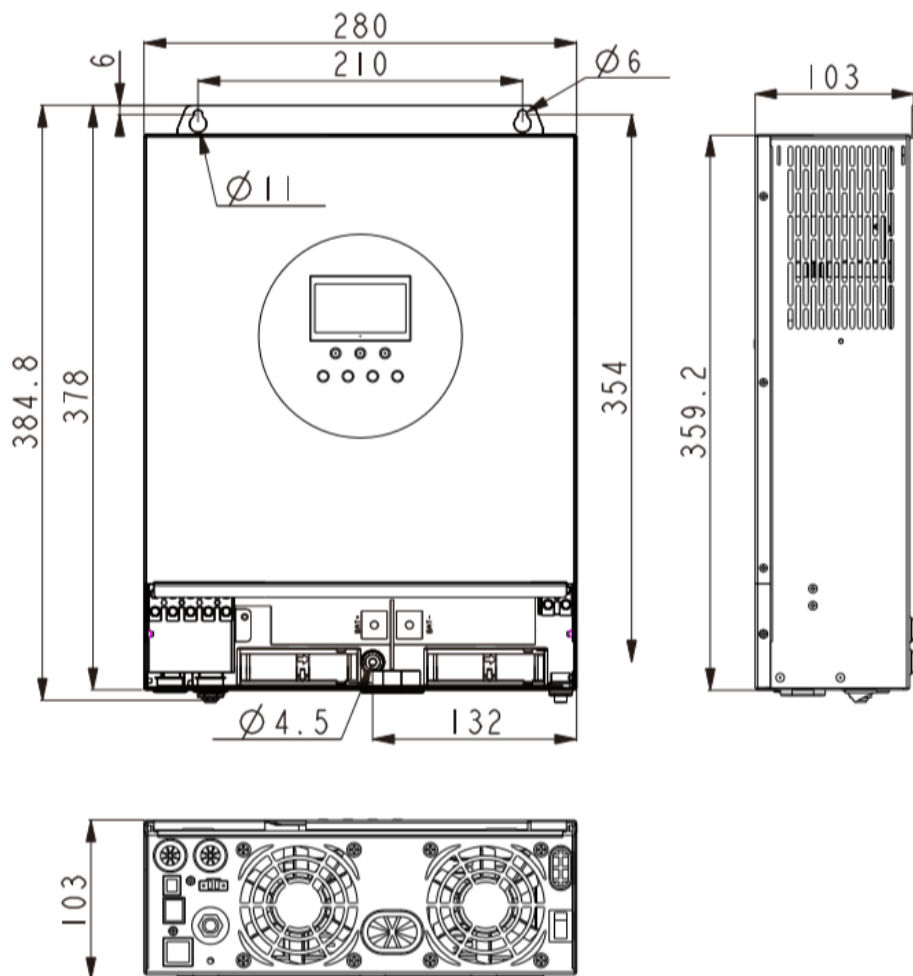

# Installation

## ■ Installation Notice

Please read this manual carefully prior to installation to familiarize yourself with the installation steps.

- Be very careful when installing the battery. Wear safety goggles when installing a lead-acid liquid battery. Once coming into contact with the battery acid, rinse with clean water timely.
- Do not place metal objects near the battery to prevent short-circuit of the battery.
- Acid gas may be generated when the battery is charged. So, please ensure good ventilation.
- When installing the cabinet, be sure to leave enough space around the all-in-one solar charge inverter for heat dissipation. Do not install the all-in-one solar charge inverter and lead-acid battery in the same cabinet to avoid corrosion by acid gas generated during battery operation.
- Only the battery that meets the requirements of the all-in-one unit can be charged.
- Poorly connected connections and corroded wires may cause great heat which will melt the wire insulation, burn the surrounding materials, and even cause fires. So, make sure the connectors have been tightened, and the wires are secured with ties to avoid looseness of connections caused by shaking of wires during mobile application.
- The system connection wires are selected according to a current density of not more than 5 A/mm<sup>2</sup>.
- Avoid direct sunlight and rainwater infiltration for outdoor installation.
- Even after the power is turned off, there is still high voltage inside the unit. Do not open or touch the internal components, and avoid related operations until the capacitor completely discharges.
- Do not install the all-in-one solar charge inverter in harsh environments such as moist, oily, flammable or explosive, or heavily dusty areas.
- Polarity at the battery input end of this product shall not be reversed, otherwise it may damage the device or cause unpredictable danger.
- The mains input and AC output are high voltage, so please do not touch the wiring terminals.
- When the fan is working, do not touch it to prevent injury.
- Load equipment input power needs to confirm that this all-in-one solar charge inverter is the only input device, and it is forbidden to use in parallel with other input AC power to avoid damage. It is necessary to confirm that the solar charge inverter is the only input device for load equipment, and it is forbidden to use it in parallel with other input AC power to avoid damage.

## ■ Select the Mount Location

### Determine the installation position and the space for heat dissipation.

- Determine the installation position of the all-in-one solar charge inverter, such as wall surface;
- When installing the all-in-one solar charge inverter, ensure that there is enough air flowing through the heat sink, and space of at least 200mm to the left and right air outlets of the inverter shall be left to ensure natural convection heat dissipation. Refer to the installation diagram of the whole machine as above.

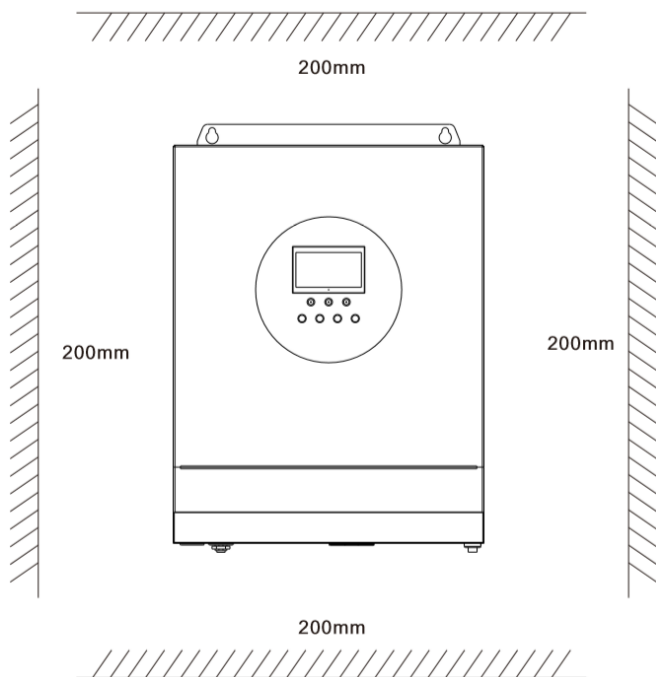

### **WARNING**

- Danger of explosion! Never install the all-in-one solar charge inverter and lead-acid battery in the same confined space! Also do not install in a confined place where battery gas may collect.

## ■ Mount the Inverter

Install the unit by screwing two screws. It's recommended to use M5 screws.

## ■ Preparation

Before connecting all wirings, please take off bottom cover by removing two screws as shown below.

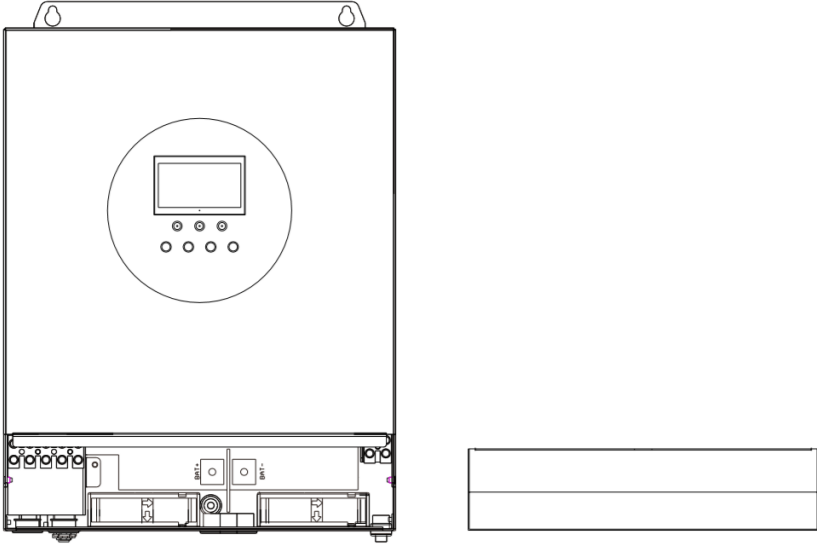

# Connection

## ■ Wiring Specification and Breaker Type

**Wiring and installation must comply with national and local electrical codes.**

Recommended PV array wiring specifications and circuit breaker selection: Since the output current of the PV array is affected by the type, connection method and illumination angle of the PV module, the minimum wire diameter of the PV array is calculated according to its short-circuit current; refer to the short-circuit current value in the PV module specification (the short-circuit current is constant when the PV modules are connected in series; the short-circuit current is the sum of the short-circuit currents of all PV modules connected in parallel); the short-circuit current of the PV array shall not exceed the maximum input current.

➤ **Please refer to the table below for PV input wire diameter and switch:**

Model	Wire Diameter	Max. PV input current	Circuit breaker Spec
POW-LVM3K-24V-H	3.5mm <sup>2</sup> /12AWG	18A	2P—25A

**Note:** The voltage in series shall not exceed the maximum PV input open circuit voltage.

➤ **Please refer to the table below for recommended AC input wire diameter and switch:**

Model	Wire Diameter	Max. bypass input current	Circuit breaker Spec
POW-LVM3K-24V-H	8mm <sup>2</sup> /8AWG	40A	2P—40A

**Note:** There is already a corresponding breaker at input connection point of mains supply. Therefore, it is not necessary to add one more.

➤ **Recommended input wire diameter and switch type for battery:**

Model	Wire Diameter	Rated Battery Discharge Current	Max. Charge Current	Circuit Breaker Spec
POW-LVM3K-24V-H	30mm <sup>2</sup> /2AWG	135A	80A	2P—160A

➤ **Recommended wire specification and breaker type for AC output:**

Model	Wire diameter	Rated Inverter AC Output current	Max. bypass output current	Circuit Breaker Spec
POW-LVM3K-24V-H	8mm <sup>2</sup> /8AWG	25A	40A	2P—40A

**Note:** The wire diameter is only for reference. In case of long distance between photovoltaic array and all-in-one inverter or between all-in-one inverter and battery, use thicker wire to reduce voltage drop and improve system performance.

## NOTICE

- Above wire diameter and breaker are only for reference. Please select appropriate wire diameter and breaker based on practical condition.

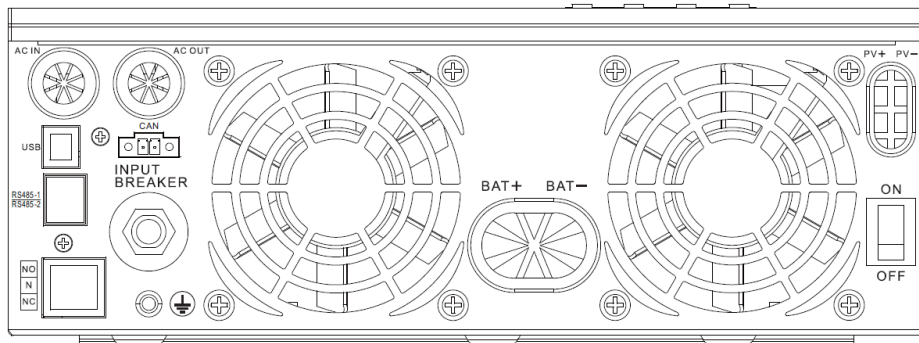

## ■ AC Input/Output Wiring

1. Prior to AC input/output wiring, disconnect the external circuit breaker and confirm that the wire used is thick enough. Please refer to Section “Wiring Specification and Breaker Type”;
2. Properly connect the AC input wire according to the wire sequence and terminal position shown in the figure below. Please connect the ground wire first, and then the live wire and the neutral wire;

 : Ground    L: Live    N: Neutral

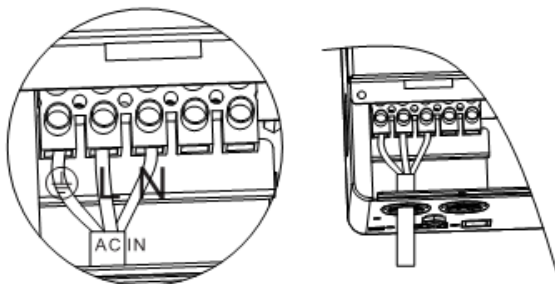

3. Properly connect the AC output wire according to the wire sequence and terminal position shown in the figure below. Please connect the ground wire first, and then the live wire and the neutral wire. The ground wire is connected to the grounding screw hole on the cabinet through the O-type terminal.

 : **Ground**    **L: Live**    **N: Neutral**

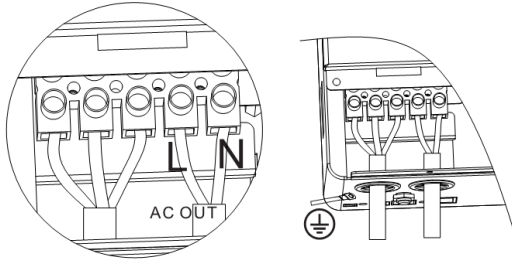

### **NOTICE**

- The grounding wire shall be as thick as possible (cross-sectional area is not less than 4mm<sup>2</sup>). The grounding point shall be as close as possible to the all-in-one solar charge inverter. The shorter the grounding wire, the better.

### **■ PV Input Wiring**

1. Before wiring, disconnect external breaker at first, and confirm whether the used cable is thick enough. Please refer to section “Wiring Specification and Breaker Type”;
2. Correctly connect PV input wire in accordance with cable sequence and terminal position shown in the figure below.

**PV+: positive input pole**      **PV-: negative input pole**

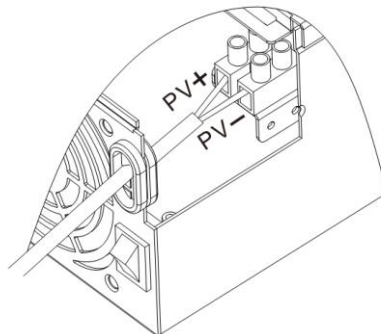

## ■ Battery Wiring

1. Prior to wiring, disconnect the external circuit breaker and confirm that the wire used is thick enough. Please refer to Section "Wiring Specification and Breaker Type". The BAT wire needs to be connected to the machine through the O-type terminal. The O-type terminal with an inner diameter of 5 mm is recommended. The O-type terminal shall firmly press the BAT wire to prevent excessive heat generation caused by excessive contact resistance;
2. Properly connect the BAT wire according to the wire sequence and terminal position shown in the figure below.

**BAT+:** positive battery pole

**BAT-:** negative battery pole

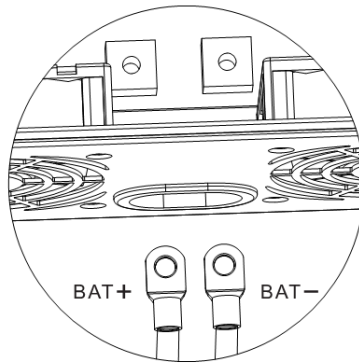

### **WARNING**

- Mains input, AC output and PV array will generate high voltage. So, before wiring, be sure to disconnect the circuit breaker or fuse;
- Be very careful during wiring; do not close the circuit breaker or fuse during wiring, and ensure that the "+" and "-" pole leads of each component are connected properly; a circuit breaker must be installed at the battery terminal. Refer to Section "Wiring Specification and Breaker Type" to select a right circuit breaker. Before wiring, be sure to disconnect the circuit breaker to prevent strong electric sparks and avoid battery short circuit; if the all-in-one solar charge inverter is used in an area with frequent lightning, it is recommended to install an external lightning arrester at the PV input terminal.

## ■ Final Assembly

1. After wiring, inspect whether the wires are correctly and firmly connected, especially whether the positive and negative input poles of the battery are correct, whether the positive and negative input poles of PV are correct, whether AC input is inaccurately connected to AC output terminal.
2. After ensuring that the wiring is reliable and the wire sequence is correct, install the terminal protection cover in place.

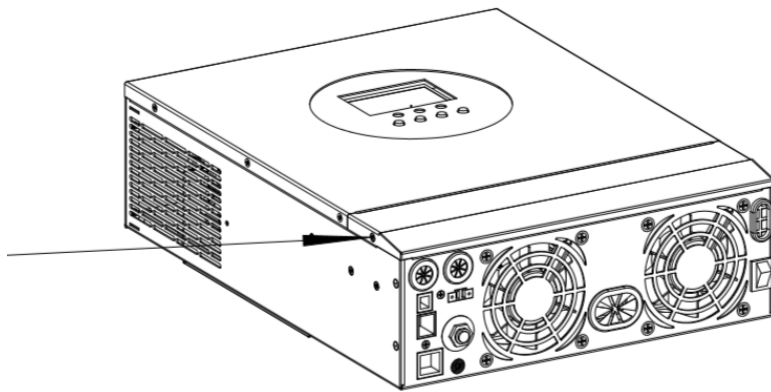

## ■ Start Up the Inverter

1. At first close the breaker at the battery end, and then press the rocker switch at the lower left side of the machine to “ON” state, “AC/INV” indicator light flashes, indicating normal operation of inverter.
2. Afterwards, close breakers of photovoltaic array and mains supply.
3. In the end, after AC output is normal, turn on AC load one by one to avoid protection action generated by great instant impact owing to simultaneous turn on the loads. The inverter operates normally in accordance with set mode.

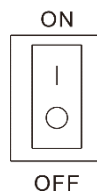

### **NOTICE**

- If power is supplied to different AC loads, it is recommended to first turn on the load with a large surge current. After the load is stable, turn on the load with a small surge current.
- If the all-in-one solar charge inverter does not work properly or the LCD or indicator is abnormal, refer to section “Troubleshooting” to handle the exceptions.

# Operation Mode

## ■ Charging Mode

The charge mode corresponds to the parameter setting item 06, allowing users' manual setting.

- 1) **Hybrid charging (SNU):** PV and mains hybrid charging. PV MPPT charging is a priority, and when PV energy is insufficient, the mains supply supplements. When the PV energy is sufficient again, the mains stops charging. This is the fastest charging mode, suitable for the areas where power grid is unstable, providing sufficient backup power supply at any time.

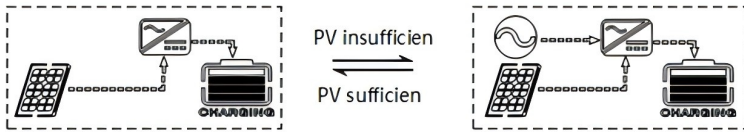

- 2) **Only Solar (OSO):** Only PV charging, without Mains charging. This is the most energy-efficient way in which battery is charged only by solar panels, and is usually used in areas with good lighting conditions.

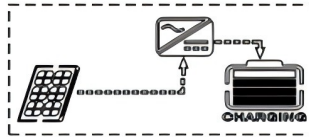

## ■ Output Mode

The AC output mode corresponds to parameter setting items of 01, allowing users' manual setting.

- 1) **PV priority mode:** Using photovoltaic, battery energy to power the load, with the photovoltaic taking priority over the load.

When the PV energy is greater than the load, the excess energy charges the battery.

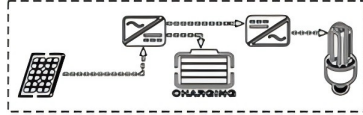

When the PV energy is less than the load, the lack of energy is replenished by the battery.

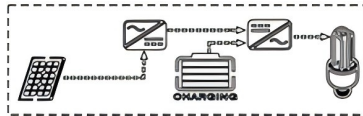

When the PV is ineffective, switch to utility power supply and charging; when the PV is restored, switch to PV and battery with load.

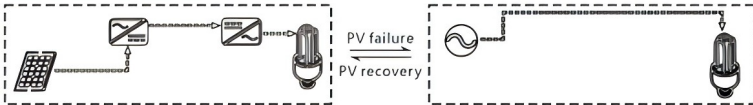

No BMS communication: when the battery voltage is lower than the 04 setting item, switch to utility power supply and charging; when the battery voltage is higher than the 05 setting item, switch to PV and battery with load.

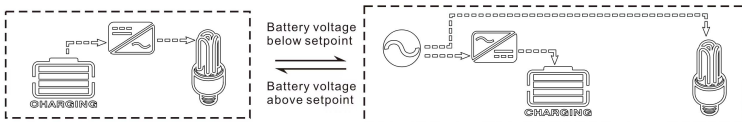

There is BMS communication: when the battery SOC is lower than 61 setting item, switch to utility power supply and charging; when the battery SOC is higher than 62 setting item, switch to PV, battery with load.

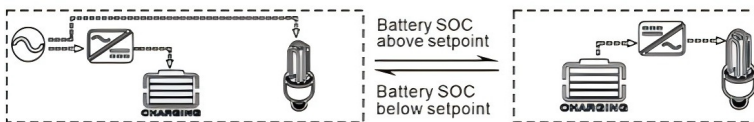

This model maximizes the use of solar energy while maintaining battery power and is suitable for areas with relatively stable power grids.

2) **Main priority mode:** Switch to inverter only when the mains fails (when there was mains power, switch to mains power for charging and power supply). Then, the unit is equivalent to a backup UPS, suitable for areas with unstable grid.

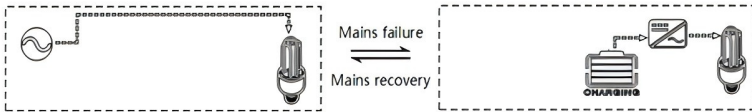

Switching does not affect PV charging.

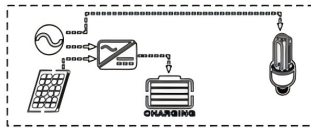

3) **Inverter priority mode:** Use of photovoltaic, battery energy to power the load, with the photovoltaic taking priority over the load.

When the PV energy is greater than the load, the excess energy charges the battery.

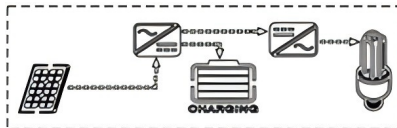

When the PV energy is less than the load, the lack of energy is replenished by the battery.

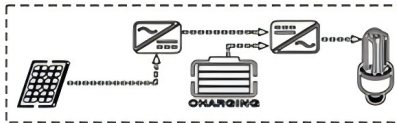

When the PV is ineffective, switch to utility power supply and charging; when the PV is restored, switch to PV and battery with load.

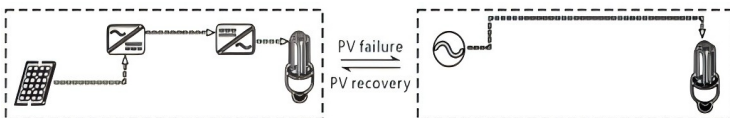

No BMS communication: when the battery voltage is lower than the 04 setting item, switch to utility power supply and charging; when the battery voltage is higher than the 05 setting item, switch to PV and battery with load.

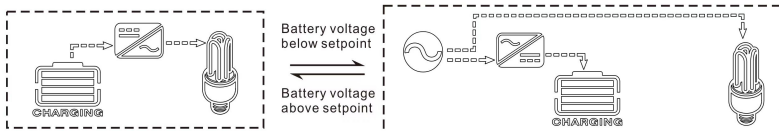

There is BMS communication: when the battery SOC is lower than 61 setting item, switch to utility power supply and charging; when the battery SOC is higher than 62 setting item, switch to PV, battery with load.

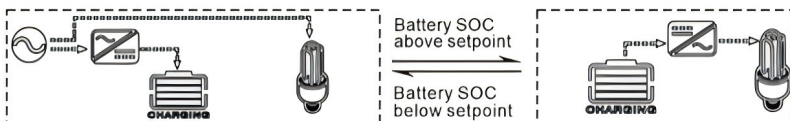

This mode maximizes the use of DC energy and is used in areas where the grid is stable. Switching does not affect PV charging.

- 3) **Mixed functions mode:** When the battery is not available or the battery is fully charged, the load is provided by PV and commercial power, PV maximum output power output.

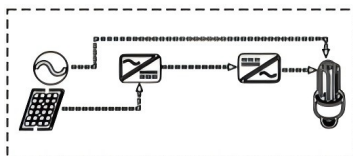

# Operation Instruction

## ■ Operation and Display Panel

The operation and display panel is as shown below, including 1 LCD screen, 3 indicators and 4 operation buttons.

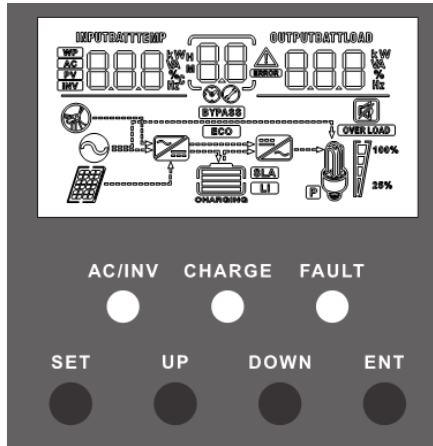

### ● Touchable Keys

Function buttons	Description
SET	Enter/Exit Settings menu
UP	Previous choice
DOWN	Next choice
ENT	Confirm/Enter Options under the settings menu







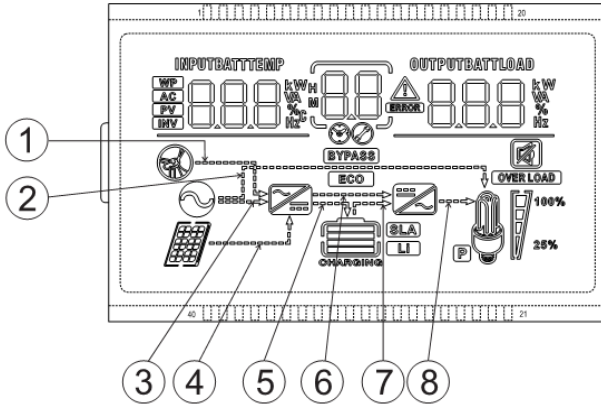

### ● LED Indicators

Indicators	Colors	Description
AC/INV	Yellow	Steady on: Mains output
		Flash: Inverter output
CHARGE	Green	Flash: Battery charging
		Steady on: Charging completed
FAULT	Red	Flash: Fault state





## ■ Introduction to LCD Screen



Icon	Function	Icon	Function
	Indicating that AC input end has been connected to power grid		Indicating that inverter circuit is in working.
	Indicates that the AC input mode in APL mode (wide voltage range)	<b>BYPASS</b>	Indicating that the machine is in mains supply bypass work mode
	Indicating that PV input end has been connected to solar battery panel	<b>OVER LOAD</b>	Indicating that AC output is in overload state
	Indicating that machine has been connected to battery, indicating 0%~24% battery remaining capacity; indicating 25%~49% battery remaining capacity; indicating 50%~74% battery remaining capacity; indicating 75%~100% battery remaining capacity.		Indicating percentage of AC output load, indicating 0%~24% load percentage; indicating 25%~49% load percentage; indicating 50%~74% load percentage; indicating ≥75% load percentage.

	Indicating that present battery type of the machine is lithium battery		Indicating that buzzer is not enabled
	Indicating that current battery type of machine is lead-acid battery		Indicating alarm of machine
<b>CHARGING</b>	Indicating that the battery is in charge state.		Indicating that the machine is in fault state.
	Indicating that AC/PV charge circuit is in working		Indicating that the machine is in setting mode.
	Indicating that AC output end has AC voltage output		The parameters displayed in the middle of the screen: 1. In the non-setup mode, the alarm or fault code is displayed. 2. In the setup mode, the currently set parameter item code is displayed.

**Parameter display at left side of screen: Input Parameter**

	Indicating AC input
	Indicating PV input
	Indicating inverter circuit
	The icon is not displayed
	Displaying battery voltage, total charge current of battery, charge power of mains supply, AC input voltage, AC input frequency, PV input voltage, temperature of internal radiator, software version

**Parameter display at right side of screen: Output Parameter**

	Indicating output voltage, output current, output active power, output apparent power, battery discharge current, software version; In setting mode, displaying the setting parameter under the parameter item code set currently
--	--

**Arrow display**

①	The arrow is not displayed	⑤	Indicates the charging circuit charging the battery terminal
②	Indicating power grid power supply to load	⑥	The arrow is not displayed

③	Indicating power grid power supply to charge circuit	⑦	Indicates the battery terminal supplying power to the inverter circuit
④	Indicating PV power supply to charge circuit	⑧	Indicating power supply from inverter circuit to load

## ■ Real-time Data Viewing Method

On the LCD main screen, press the “UP” and “DOWN” buttons to scroll through the real-time data of the machine.

Page	Left Parameter of Screen	Middle Parameter of Screen	Right Parameter of Screen
1	INPUT BATT V (Battery input voltage)	Fault code	OUTPUT LOAD V (Output load voltage)
2	PV TEMP °C (PV charger heatsink temperature)		PV OUTPUT KW (PV output power)
3	PV INPUT V (PV input voltage)		PV OUTPUT A (PV output current)
4	INPUT BATT A (Input battery current)		OUTPUT BATT A (Battery output current)
5	INPUT BATT KW (Battery input power)		OUTPUT BATT KW (Battery output power)
6	AC INPUT Hz (AC input frequency)		AC OUTPUT LOAD Hz (AC output frequency)
7	AC INPUT V (AC input voltage)		AC OUTPUT LOAD A (AC output load current)
8	INPUT V (For maintain)		OUTPUT LOAD KVA (Load apparent power)
9	INV TEMP °C (AC charge or battery discharge heatsink temperature)		INV OUTPUT LOAD KW (Load active power)
10	APP software version		Bootloader software version
11	Model Battery Voltage Rating		Model Output Power Rating
12	Model PV Voltage Rating		Model PV Current Rating

## ■ Setting Parameter

Buttons operation instructions: Press the “SET” button to enter the setup menu and exit the setup menu. After entering the setup menu, the parameter number [00] will flash. At this point, press the “UP” and “DOWN” buttons to select the code of parameter item to be set. Then, press the “ENT” button to enter the parameter editing mode, and the value of the parameter is flashing. Adjust the value of the parameter with the “UP” and “DOWN” buttons. Finally, press the “ENT” button to complete the parameter editing and return to the parameter selection state.

No.	Description	Selectable option	
00	Exit setting menu	[00] ESC	Exit the setup menu
01	Output source priority	[01] SOL	PV priority mode, switching to the Mains when the PV fails or the battery is lower than the set value of parameter [04].
		[01] UTI	Photovoltaic energy priority with the load, photovoltaic is not enough, the grid power and photovoltaic mixed load, photovoltaic energy is enough with the load, the excess energy to charge the battery, the grid power only starts charging when the battery is too discharged (06 Settings as”OSO(only PV)”, the grid power will not charge), the battery is only discharged when off the grid.
		[01] SBU	Inverter priority mode, switching to the mains only when the battery is under voltage or lower than the set value of parameter [04].
		[01]SUB <b>default</b>	Solar energy priority charging, insufficient solar energy, grid energy and solar energy hybrid charging (if 06

No.	Description	Selectable option	
			Settings as" OSO(only PV ) "; the grid energy will not charge) and grid with load, when solar energy is enough to charge,excess energy not enough to load, excess solar energy and grid will hybrid load, the battery is discharged only when off the grid.
02	Output Frequency	[02] 50.0	Bypass self-adaptation; when the mains is connected, it automatically adapts to the mains frequency; when the mains is disconnected, the output frequency can be set through this menu. The default output frequency of the 120V machine 60Hz.
		[02] 60.0	
03	AC Input Voltage Range	[03] APL	Mains input voltage range of 120V machine: 90~140V
		[03] UPS <b>default</b>	Mains input voltage range of 120V machine: 90~140V
04	Battery Power to Utility Setpoint	[04] 24V <b>default</b>	When the parameter [01] =SOL/SBU, the battery voltage is lower than the set value, and the output is switched from the inverter to the mains. Setting range: 20V~30V. Cannot exceed the value of [14] settings.
05	Utility to Battery Power Setpoint	[05] 28V <b>default</b>	When the parameter [01] =SOL/SBU, the battery voltage is higher than the set value, and the output is switched from the mains to the inverter. Setting

No.	Description	Selectable option	
			range: 24V~30V. Cannot be lower than the value of [04] / [35] settings.
06	Charge mode	[06] SUN <b>default</b>	PV and Mains hybrid charging; PV charging is a priority, and when the PV energy is insufficient, the Mains charging supplements. When the PV energy is sufficient, the Mains charging stops. Note: Only when the Mains bypass output is loaded, the PV charging and the mains charging can work at the same time. When the inverter works, only the PV charging can be started.
		[06] OSO	Only PV charging, with the Mains charging not activated.
07	Max charger current	[07] 80A <b>default</b>	Max. charger current (AC charger+PV charger). Setting range: 0~80A.
08	Battery Type	[08] USE	User-defined; all battery parameters can be set.
		[08] SLd	Sealed lead-acid battery; constant-voltage charge voltage: 28.8V, floating charge voltage: 27.6V.
		[08] FLd	Vented lead-acid battery; constant-voltage charge voltage: 29.2V, floating charge voltage: 27.6V.
		[08] GEL <b>default</b>	Colloidal lead-acid battery; constant-voltage charge voltage: 28.4V, floating charge voltage: 27.6V.

No.	Description	Selectable option	
		[08] LF07/LF08/LF09	Lithium iron phosphate battery LF07/LF08/LF09, corresponding to 7 strings ,8 strings and 9 strings of lithium iron phosphate battery; for 7 strings, default constant-voltage charge voltage is 24.8V; for 8 strings, default constant-voltage charge voltage is 28.4V; for 9 strings, default constant-voltage charge voltage is 31.8V; allow adjustable.
		[08] N07/N08	Ternary lithium battery; the default constant-voltage charge voltage is 28.4V, which is adjustable.
<b>09</b>	Battery boost charge voltage	[09] 28.8V <b>default</b>	Boost charge voltage setting; the setting range is 24V~29.2V, with step of 0.2V; it is valid for user-defined battery and lithium battery.
<b>10</b>	Battery boost charge time	[10] 120 <b>default</b>	Boost charge maximum time setting, which means the maximum charging time to reach the set voltage of parameter [09] during constant-voltage charging. The setting range is 5min~900min, with a step of 5 minutes. It is valid for user-defined battery and lithium battery.
<b>11</b>	Battery floating charge voltage	[11] 27.6V <b>default</b>	Floating charge voltage, setting range: 24V~29.2V, step: 0.2V, valid when battery type is user-defined.

No.	Description	Selectable option	
12	Battery over discharge voltage (delay off)	[12] 21V <b>default</b>	Over-discharge voltage: when the battery voltage is lower than this judgment point, delay the time set by parameter [13] and turn off inverter output. Setting range is 20V~24V, with a step of 0.2V. It is valid for user-defined battery and lithium battery.
13	Battery over discharge delay time	[13] 5S <b>default</b>	Over-discharge delay time: when the battery voltage is lower than the parameter [12], the inverter output will be turned off after the time set by this parameter is delayed. The setting range is 5s~50s, with a step of 5s. It is valid for user-defined battery and lithium battery.
14	Battery under voltage alarm	[14] 22V <b>default</b>	Battery undervoltage alarm point: when the battery voltage is lower than the point, an undervoltage alarm is given, and the output is not turned off; the setting range is 20V~26V, with a step of 0.2V. It is valid for user-defined battery and lithium battery.
15	Battery discharge limit voltage	[15] 20V <b>default</b>	Battery discharge limit voltage: When the battery voltage is lower than the point, the output is turned off immediately; the setting range is 20V~26V, with a step of 0.2V. It is valid for user-defined battery and lithium battery.

No.	Description	Selectable option	
16	Battery equalization enable	[16] DIS	Equalizing charge is disabled
		[16] ENA <b>default</b>	Equalizing charge is enable, only valid for vented lead-acid battery and sealed lead-acid battery.
17	Battery equalization voltage	[17] 29.2V <b>default</b>	Equalizing charge voltage: Setting range: 24V~29.2V, with a step of 0.2V; valid for vented lead-acid battery and sealed lead-acid battery
18	Battery equalized time	[18] 120 <b>default</b>	Equalizing charge time: Setting range: 5min~900min, with a step of 5 minutes; valid for vented lead-acid battery and sealed lead-acid battery
19	Battery equalized time out	[19] 120 <b>default</b>	Equalizing charge delay: Setting range: 5min~900min, with a step of 5 minutes; valid for vented lead-acid battery and sealed lead-acid battery
20	Battery equalization interval	[20] 30 <b>default</b>	Equalizing charge derating time, 0~30days, with a step of 1 day; valid for vented lead-acid battery and sealed lead-acid battery
21	Battery equalization immediately	[21] DIS	Stop equalizing charge immediately.
		[21] ENA <b>default</b>	Start equalizing charge immediately.
22	Power saving mode	[22] DIS <b>default</b>	Power saving mode disabled.
		[22] ENA	After the power saving mode is enabled, if the load is null or less than 50W, the inverter output is turned off after a delay for a certain period of time. When the load is more than 50W, the inverter automatic restart.

No.	Description	Selectable option	
23	Restart when over load	[23] DIS	Automatic restart when overload is disabled. If an overload occurs and the output is turned off, the machine will not restart.
		[23] ENA <b>default</b>	Automatic restart when overload is enabled. If an overload occurs and the output is turned off, the machine will restart after a delay of 3 minutes. After it reaches 5 cumulative times, the machine will not restart.
24	Restart when over temperature	[24] DIS	Automatic restart when over temperature is disabled. If an over-temperature shutdown occurs, machine will not restart to turn the output on.
		[24] ENA <b>default</b>	Automatic restart when over temperature is enabled. If an over-temperature shutdown occurs, the machine will restart when the temperature drops.
25	Alarm enable	[25] DIS	Alarm is disabled
		[25] ENA <b>default</b>	Alarm is enabled
26	Beeps while primary source is interrupted	[26] DIS	Alarm beep is disabled when the status of the main input source changes
		[26] ENA <b>default</b>	Alarm beep is enabled when the status of the main input source changes
27	Bypass output when overload	[27] DIS	It is disabled to automatically switch to the Mains when the inverter is overloaded.

No.	Description	Selectable option	
		[27] ENA <b>default</b>	It is enabled to automatically switch to the Mains when the inverter is overloaded.
28	Max AC charger current	[28] 40A <b>default</b>	Max AC charger current. Setting range: 0~40A;
29	Split Phase	[29] DIS <b>default</b>	Supply for industrial frequency transformer (disabled)
		[29] ENA	Supply for industrial frequency transformer (enabled)
30	RS485 Address Setting	[30] 1 <b>default</b>	RS485 communication address can be set within the range of 1~254 for stand-alone mode.
32	RS485/CAN communication	[32] DIS <b>default</b>	RS485 port for PC or telecommunication control.
		[32] BMS	RS485 port for BMS communication.
		[32] CAN	CAN port for BMS CAN communication function
33	Battery BMS communication protocol	When the parameter [32] setting item =BMS, you can choose to match the battery manufacturer's BMS protocol to communicate with BMS for the lithium battery protection.	
		485: PAC=PACE, RDA=RITAR, AOG=ALLGRAND BATTERY, OLT=OLITER, HWD=SUNWODA, DAQ=DYNESS WOW=SRNE, PYL=PYLONTECH, UOL=WEILAN, UOL=VILION, SHO=FOX ESS, XXI=Xinyienergy, POW=PowMr, CEF=CFGE, SGP=SGP, GSL=GSL energy, CEF=CFGE CAN: SGP=SGP, GSL=GSL energy, WOW=SRNE, UZE=UZ Energy	

No.	Description	Selectable option	
35	Battery undervoltage recovery point	[35] 26V <b>default</b>	When the battery voltage is under voltage, the battery voltage needs to recover more than this set value before the inverter starts the output.
36	PV maximum charging current	[36] 80A <b>default</b>	Maximum solar charging current setting: 0~80A.
37	Battery fully charged recovery point	[37] 26V <b>default</b>	After the battery is fully charged, it needs to be lower than this set voltage before it can be recharged
38	AC output voltage setting (only can be set in the standby mode)	[38] 120Vac <b>default</b>	Allow to set to 100Vac/ 105Vac/ 110Vac/ 120Vac/ 127Vac. The rated output power will be reduced = (Power Rate)*(Vset/120)
57	Stop charging current	[57] 2A <b>default</b>	Charging stops when the default charging current is less than this setting
58	Discharge alarm SOC setting	[58] 15% <b>default</b>	SOC alarm when capacity is less than this set value (valid when BMS communication is normal)
59	Cut-off discharge SOC Settings	[59] 5% <b>default</b>	Stops discharging when the capacity is less than this setting (valid when BMS communication is normal)
60	Cut-off charge SOC Settings	[60] 100% <b>default</b>	Stops charging when capacity is greater than or equal to this setting (valid when BMS communication is normal)
61	Switch to mains SOC Settings	[61] 10% <b>default</b>	Switch to mains when capacity is less than this setting (valid when BMS communication is normal)

No.	Description	Selectable option	
62	Switch to inverter output SOC Settings	[62] 100% <b>default</b>	Switches to inverter output mode when capacity is greater than or equal to this setting (valid when BMS communication is normal)
63	N-PE connection auto switching function	[63] DIS <b>default</b>	Automatic switching of N-PE connections is not allowed
		[62] ENA	Allows automatic switching of N-PE connections

## ■ Battery Type Parameters

For Lead-acid Battery:

Battery type Parameters	Sealed lead acid battery (SLD)	Colloidal lead acid battery (GEL)	Vented lead acid battery (FLD)	User-defined (User)
Overvoltage disconnection voltage	30.0V	30.0V	31.0V	18~30V
Battery fully charged recovery point (setup item 37)	26V (Adjustable)	26V (Adjustable)	26V (Adjustable)	26V (Adjustable)
Equalizing charge voltage	29.2V	-	29.6V	18~30V
Boost charge voltage	28.8V	28.4V	29.2V	18~30V (Adjustable)
Floating charge voltage	27.6	27.6V	27.6V	18~30V (Adjustable)
Undervoltage alarm voltage (01 fault)	22V	22V	22V	18~30V (Adjustable)
Undervoltage alarm voltage recovery point (01 fault)	Undervoltage alarm voltage+0.4V			
Low voltage disconnection voltage (04 fault)	21.0V	21.0V	21.0V	18~30V (Adjustable)
Low voltage disconnection voltage recovery point (04 fault) (setup item 35)	26V (Adjustable)	26V (Adjustable)	26V (Adjustable)	26V (Adjustable)
Discharge limit voltage	20.0V	20.0V	20.0V	18~30V (Adjustable)
Over-discharge delay time	5s	5s	5s	1~30s (Adjustable)
Equalizing charge duration	120 mins	-	120 mins	0~600 mins (Adjustable)
Equalizing charge interval	30 days	-	30 days	0~250 days (Adjustable)
Boost charge duration	120 mins	120 mins	120 mins	10~600 mins (Adjustable)

**For Lithium Battery :**

<b>Battery Type</b> <b>Parameters</b>	<b>Ternary lithium battery (N07)</b>	<b>Ternary lithium battery (N08)</b>	<b>Lithium iron phosphate battery (LF07)</b>	<b>Lithium iron phosphate battery (LF08)</b>	<b>Lithium iron phosphate battery (LF09)</b>
Overvoltage disconnection voltage	31.6V	33V	30V	30V	33V
Battery fully charged recovery point (setup item 37)	27.4V (Adjustable)	30.4V (Adjustable)	23.2V (Adjustable)	26.8V (Adjustable)	29.8V (Adjustable)
Equalizing charge voltage	28.8V (Adjustable)	31.6V (Adjustable)	24.6V (Adjustable)	28.4V (Adjustable)	31.6V (Adjustable)
Boost charge voltage	28.8V (Adjustable)	31.6V (Adjustable)	24.6V (Adjustable)	28.4V (Adjustable)	31.6V (Adjustable)
Floating charge voltage	28.8V (Adjustable)	31.6V (Adjustable)	24.6V (Adjustable)	28.4V (Adjustable)	31.6V (Adjustable)
Undervoltage alarm voltage (01 fault)	23.4V (Adjustable)	26.8V (Adjustable)	21.6V (Adjustable)	24.8V (Adjustable)	27.8V (Adjustable)
Undervoltage alarm voltage recovery point (01 fault)	Undervoltage alarm voltage+0.4V				
Low voltage disconnection voltage (04 fault)	21.0V (Adjustable)	24.0V (Adjustable)	21.0V (Adjustable)	24.4V (Adjustable)	27.0V (Adjustable)
Low voltage disconnection voltage recovery point (04 fault) (setup item 35)	26V (Adjustable)	29.6V (Adjustable)	23.8V (Adjustable)	27.2V (Adjustable)	30.6V (Adjustable)
Discharge limit voltage	19.6V	22.4V	20.4V	23.2V	26.2V
Over-discharge delay time	30s (Adjustable)	30s (Adjustable)	30s (Adjustable)	30s (Adjustable)	30s (Adjustable)
Equalizing charge duration	-	-	-	-	-
Equalizing charge interval	-	-	-	-	-
Boost charge duration	120 mins	120 mins	120 mins	120 mins	120 mins

# Other Function

## ■ Dry Node

Working principle: This dry node can control the ON/OFF of the diesel generator to charge the battery.

- ① Normally, the terminals are that the NC-N point is closed and the NO-N point is open;
- ② When the battery voltage reaches the low voltage disconnection point, the relay coil is energized, and the terminals turn to that the NO-N point is closed while NC-N point is open. At this point, NO-N point can drive resistive loads: 125VAC/1A, 230VAC/1A, 30VDC/1A.

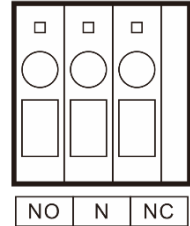

## ■ RS485 Communication Port

This port is an RS485 communication port which comes with two functions:

- ① WiFi/RS485 communication port can be used for RS485 communication with lithium battery BMS (5 pins for RS485A, 6 pins for RS485B);
- ② It also allows direct connection with the optional RS485 to WiFi/GPRS communication module developed by our company through this port. After the module is selected, you can connect the all-in-one solar charge inverter through the mobile phone WiFi/GPRS APP, on which you can view the operating parameters and status of the device.

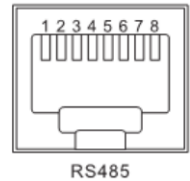

As shown in the figure:

Pin 1 is 5V power supply, pin 2 is GND, pin 5 is RS485-A2, pin 6 is RS485-B2, pin 7 is RS485-A1, pin 8 is RS485-B1. (Pin 5 and 6 are A and B wiring sequence for BMS communication; Pin 7 and 8 are A and B wiring sequence for WIFI module communication or host computer communication, B wiring sequence for WIFI module communication or host computer communication.)

## ■ CAN Communication Function

Function of connecting lithium battery communication.

As shown in the figure:

Pin 1 is CAN-L, and Pin 2 is CAN-H.

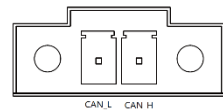

## ■ USB communication port

This is a USB communication port, which can be used for USB communication with the optional PC host software. To use this port, you should install the corresponding "USB to serial chip CH340T driver" and APP in the computer.

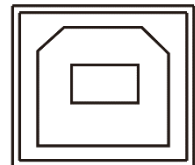

# Protection

## ■ Protections Provided

No.	Protections	Description
1	PV current/power limiting protection	When charging current or power of the PV array configured exceeds the PV rated, it will charge at the rated.
2	PV night reverse-current protection	At night, the battery is prevented from discharging through the PV module because the battery voltage is greater than the voltage of PV module.
3	Mains input over voltage protection	When the mains voltage exceeds 140V (120V model), the mains charging will be stopped and switched to the inverter mode.
4	Mains input under voltage protection	When the mains voltage is lower than 90V (120V model or APL mode), the mains charging will be stopped and switched to the inverter mode.
5	Battery over voltage protection	When the battery voltage reaches the overvoltage disconnection point, the PV and the mains will be automatically stopped to charge the battery to prevent the battery from being overcharged and damaged.
6	Battery low voltage protection	When the battery voltage reaches the low voltage disconnection point, the battery discharging will be automatically stopped to prevent the battery from being over-discharged and damaged.
7	Load output short circuit protection	When a short-circuit fault occurs at the load output terminal, the AC output is immediately turned off and turned on again after 1 second.
8	Heat sink over temperature protection	When the internal temperature is too high, the all-in-one machine will stop charging and discharging; when the temperature returns to normal, charging and discharging will resume.

9	Overload protection	Output again 3 minutes after an overload protection, and turn the output off after 5 consecutive times of overload protection until the machine is re-powered. For the specific overload level and duration, refer to the technical parameters table in the manual.
10	PV reverse polarity protection	When the PV polarity is reversed, the machine will not be damaged.
11	AC reverse protection	Prevent battery inverter AC current from being reversely input to Bypass.
12	Bypass over current protection	Built-in AC input overcurrent protection circuit breaker.
13	Battery input over current protection	When the discharge output current of the battery is greater than the maximum value and lasts for 1 minute, the AC input would switch to load.
14	Battery input protection	When the battery is reversely connected or the inverter is short-circuited, the battery input fuse in the inverter will blow out to prevent the battery from being damaged or causing a fire.
15	Charge short protection	When the external battery port is short-circuited in the PV or AC charging state, the inverter will protect and stop the output current.

## ■ Fault Code Meaning

Fault Code	Fault Name	Affecting Output or Not	Description
【01】	BatVoltLow	Yes	Battery undervoltage alarm
【02】	BatOverCurrSw	Yes	Battery discharge average current overcurrent software protection
【03】	BatOpen	Yes	Battery not-connected alarm
【04】	BatLowEod	Yes	Battery undervoltage stop discharge alarm
【05】	BatOverCurrHw	Yes	Battery overcurrent hardware protection
【06】	BatOverVolt	Yes	Charging overvoltage protection
【07】	BusOverVoltHw	Yes	Bus overvoltage hardware protection
【08】	BusOverVoltSw	Yes	Bus overvoltage software protection
【09】	PvVoltHigh	No	PV overvoltage protection
【10】	PvBuckOCSw	No	Buck overcurrent software protection
【11】	PvBuckOCHw	No	Buck overcurrent hardware protection
【12】	bLineLoss	No	Mains power down
【13】	OverloadBypass	Yes	Bypass overload protection
【14】	OverloadInverter	Yes	Inverter overload protection
【15】	AcOverCurrHw	Yes	Inverter overcurrent hardware protection
【17】	InvShort	Yes	Inverter short circuit protection
【19】	OverTemperMppt	No	Buck heat sink over temperature protection
【20】	OverTemperInv	Yes	Inverter heat sink over temperature protection
【21】	FanFail	Yes	Fan failure
【22】	EEPROM	Yes	Memory failure
【23】	ModelNumErr	Yes	Model setting error
【26】	RlyShort	Yes	Inverted AC Output Backfills to Bypass AC Input

<b>【29】</b>	BusLow	Yes	Internal battery boost circuit failure
<b>【32】</b>	BatCapacityLowStop	Yes	Inverter stops when battery capacity is low (setting BMS to enable validity)
<b>【34】</b>	CanCommFault	Yes	CAN communication fault in parallel operation
<b>【58】</b>	BMS communication error	NO	Check whether the communication line is connected correctly and whether [33] is set to the corresponding lithium battery communication protocol
<b>【59】</b>	BMS alarm	NO	Check the BMS fault type and troubleshoot battery problems
<b>【60】</b>	BMS battery low temperature alarm	NO	BMS alarm battery low temperature
<b>【61】</b>	BMS battery over temperature alarm	NO	BMS alarm battery over temperature
<b>【62】</b>	BMS battery over current alarm	NO	BMS alarm battery over current
<b>【63】</b>	BMS low battery alarm	NO	BMS alarm low battery
<b>【64】</b>	BMS battery over voltage alarm	NO	BMS alarm battery over voltage

## ■ Troubleshooting

Fault code	Faults	Handling measures
Display	No display on the screen	Check if the battery air switch or the PV air switch has been closed; if the switch is in the "ON" state; press any button on the screen to exit the screen sleep mode.
【06】	Battery overvoltage protection	Measure if the battery voltage exceeds rated, and turn off the PV array air switch and Mains air switch.
【01】 【04】	Battery undervoltage protection	Charge the battery until it returns to the low voltage disconnection recovery voltage.
【21】	Fan failure	Check if the fan is not turning or blocked by foreign object.
【19】 【20】	Heat sink over temperature protection	When the temperature of the device is cooled below the recovery temperature, normal charge and discharge control is resumed.
【13】 【14】	Bypass overload protection, inverter overload protection	① Reduce the use of power equipment; ② Restart the unit to resume load output.
【17】	Inverter short circuit protection	① Check the load connection carefully and clear the short-circuit fault points; ② Re-power up to resume load output.
【09】	PV overvoltage	Use a multimeter to check if the PV input voltage exceeds the maximum allowable input voltage rated.
【03】	Battery missed alarm	Check if the battery is not connected or if the battery circuit breaker is not closed.
【26】	Inverted AC Output Backfills to Bypass AC Input	Disconnect the AC input, PV input and battery input. After the screen is off, only connect the battery and start up. If fault 26 is reported, it indicates that the AC input relay switch is short-circuited, and you need to contact the manufacturer to replace it.

# System Maintenance

➤ **In order to maintain the best long-term performance, it is recommended to conduct following checks twice a year.**

1. Make sure that the airflow around the unit is not blocked and remove any dirt or debris from the heat sink.
2. Check that all exposed wires are damaged by exposure to sunlight, friction with other objects around them, dryness, bite by insects or rodents, etc., and the wires shall be repaired or replaced if necessary.
3. Verify for the consistency of indication and display with the operation of the device. Please pay attention to the display of any faults or errors, and take corrective actions if necessary.
4. Check all wiring terminals for corrosion, insulation damage, signs of high temperature or burning/discoloration, and tighten the screws.
5. Check for dirt, nesting insects and corrosion, and clean up as required.
6. If the arrester has failed, replace in time to prevent lightning damage to the unit or even other equipment of the user.

## **WARNING**

- Danger of electric shock! When doing the above operations, make sure that all power supplies of the all-in-one machine have been disconnected, and all capacitors have been discharged, and then check or operate accordingly!

➤ The company does not assume any liability for damage caused by:

- ① Improper use or use in improper site.
- ② Open circuit voltage of the PV module exceeds the maximum allowable voltage rated.
- ③ Temperature in the operating environment exceeds the limited operating temperature range.
- ④ Disassemble and repair the all-in-one solar charge inverter without permission.
- ⑤ Force majeure: Damage that occurs in transportation or handling of the all-in-one solar charge inverter.

# Technical Parameter

Models	POW-LVM3K-24V-H
<b>AC mode</b>	
Rated input voltage	110/120Vac
Input voltage range	(90Vac-140Vac) $\pm 2\%$
Frequency	50Hz/ 60Hz (Auto detection)
Frequency Range	47 $\pm$ 0.3Hz ~ 55 $\pm$ 0.3Hz (50Hz); 57 $\pm$ 0.3Hz ~ 65 $\pm$ 0.3Hz (60Hz);
Overload/short circuit protection	Circuit breaker
Efficiency	>95%
Conversion time (bypass and inverter)	10ms (typical)
AC reverse protection	Available
Maximum bypass overload current	40A
<b>Inverter mode</b>	
Output voltage waveform	Pure sine wave
Rated output power (VA)	3000
Rated output power (W)	3000
Power factor	1
Rated output voltage (Vac)	120Vac
Output voltage error	$\pm 5\%$
Output frequency range (Hz)	50Hz $\pm$ 0.3Hz; 60Hz $\pm$ 0.3Hz
Maximum Efficiency	>92%
Overload protection	(102% < load < 110%) $\pm 10\%$ : report error and turn off the output after 5 minutes; (110% < load < 125%) $\pm 10\%$ : report error and turn off the output after 10 seconds; Load >125% $\pm 10\%$ : report error and turn off the output after 5 seconds;

Peak power	6000VA
Loaded motor capability	2HP
Rated battery input voltage	24V (Minimum starting voltage 22V)
Battery voltage range	Undervoltage alarm/ shutdown voltage/ overvoltage alarm / overvoltage recovery... settable on LCD screen)
Power saving mode	Load ≤ 50W
<b>AC charging</b>	
Battery type	Lead acid or lithium battery
Maximum charge current (can be set)	0-40A
Charge current error	± 5A <sub>dc</sub>
Charge voltage range	20 - 33V <sub>dc</sub>
Short circuit protection	Circuit breaker and blown fuse
Circuit breaker specifications	40A
Overcharge protection	Alarm and turn off charging after 1 minute
<b>PV charging</b>	
Maximum PV open circuit voltage	450V <sub>dc</sub>
PV operating voltage range	120~450V <sub>dc</sub>
MPPT voltage range	120~400V <sub>dc</sub>
Battery voltage range	20~33V <sub>dc</sub>
Maximum input power	4000W
PV charging current range (can be set)	0~80A
Charging short circuit protection	Blown fuse
Wiring protection	Reverse polarity protection
<b>Hybrid charging Max charger current specifications (AC charger + PV charger)</b>	
Max charger current (can be set)	0~80A

<b>Certified specifications</b>	
Certification	CE(IEC 62109-1)/FCC/SAA
EMC certification level	EN61000, C2
Operating temperature range	-10°C ~ 55°C
Storage temperature range	-25°C ~ 60°C
Humidity range	5% to 95% (Conformal coating protection)
Noise	≤60dB
Heat dissipation	Forced air cooling, variable speed of fan
Communication interface	USB/CAN/RS485(WiFi/GPRS)/Dry node control
Size (L*W*D)	378mm*280mm*103mm
Weight (kg)	8



# POWMr

**SHENZHEN HEHEJIN INDUSTRIAL CO.,LTD**

---

**Tel/Fax:** +86 755-28219903

**Email:** [support@powmr.com](mailto:support@powmr.com)

**Web:** [www.powmr.com](http://www.powmr.com)

**Add:** Henggang Street, Longgang District, Shenzhen, Guangdong, China