

# DHN-54X16(BB) 430~445W

High Efficiency Single Glass PV Module

## Comprehensive Products & System Certificates

IEC 61215 / IEC 61730 / CE / INMETRO  
ISO 45001  
2018/International standards for occupational health & safety  
ISO 14001  
2015/Standards for environmental management system  
ISO 9001  
2015/Quality management system

 Material & technology warranty

 Linear power output warranty



Higher power, longer service life, linear power warranty for 30 years



TOPCon cells have a lower decay rate,  
 $\leq 1\%$  in the first year and  $\leq 0.4\%$  in the second year



Lower temperature coefficient,  
better high-temperature resistance, reduced power loss



Better weak light performance, higher power generation under  
low light conditions, with 0.5% -1% more power generation



LECO laser assisted sintering technology,  
reduces contact resistance and improves efficiency by 0.2% -0.5%

# DHN-54X16(BB) 430~445W

## Design

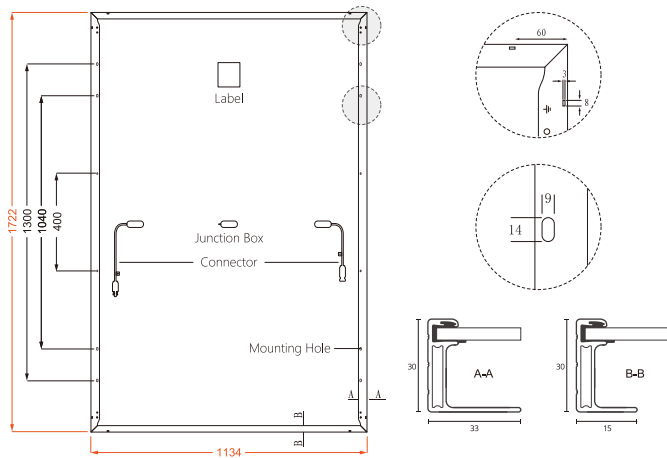

## 30-Year Linear Power Output Warranty



- DAH Solar linear power output guarantee
- Standard linear power output guarantee

## Mechanical Specification

No. of Cells	108 (6×18)
Weight	20.8kg
Cells Type	N-type 182×91mm
Dimension (L×W×T)	1722×1134×30mm
Packing	36pcs/Pallet, 936pcs/40HQ

Cable(Including connector)	4.0mm <sup>2</sup> , 300/200mm in length, length can be customized
Glass	3.2mm High Transmission, Antireflection Coating
Junction box	IP68, 3 Bypass Diodes
Connector	MC4 Compatible

## STC-Electrical Characteristics

Module Type	DHN-54X16(BB)			
	430	435	440	445
Maximum Power (P <sub>max</sub> /W)	430	435	440	445
Open-circuit Voltage (V <sub>oc</sub> /V)	38.0	38.2	38.4	38.6
Maximum Power Voltage (V <sub>mp</sub> /V)	32.5	32.7	32.9	33.1
Short-circuit Current (I <sub>sc</sub> /A)	13.84	13.90	13.96	14.02
Maximum Power Current (I <sub>mp</sub> /A)	13.23	13.30	13.37	13.44
Module Efficiency (%)	22.02	22.28	22.53	22.79

STC-Standard Test Environment: Irradiance 1000W/m<sup>2</sup>, Cell temperature 25°C, Spectrum AM1.5

## NOCT-Electrical Characteristics

Maximum Power (P <sub>max</sub> /W)	323	327	331	335
Open-circuit Voltage (V <sub>oc</sub> /V)	36.10	36.29	36.48	36.67
Maximum Power Voltage (V <sub>mp</sub> /V)	30.88	31.07	31.26	31.45
Short-circuit Current (I <sub>sc</sub> /A)	11.17	11.22	11.27	11.32
Maximum Power Current (I <sub>mp</sub> /A)	10.47	10.53	10.59	10.64

NOCT-Standard Test Environment: Irradiance 800W/m<sup>2</sup>, Ambient temperature 20°C, Spectrum AM1.5, Wind speed 1m/s

## Operating Parameters

Maximum System Voltage	1500V DC
Operating Temperature	-40 ~ +85°C
Maximum Series Fuse Rating	25A
Nominal Operating Cell Temperature	45°C±2°C
Application Level	Class A

## Temperature Coefficient

Temperature Coefficient of I <sub>sc</sub> (α <sub>Isc</sub> )	0.046%/°C
Temperature Coefficient of V <sub>oc</sub> (β <sub>Voc</sub> )	-0.25%/°C
Temperature Coefficient of P <sub>max</sub> (γ <sub>Pmp</sub> )	-0.29%/°C
Snow load, frontside / Wind load, backside	5400Pa/2400Pa